

# Introduction to Loudspeakers and Enclosures

D. G. Meyer

School of Electrical & Computer  
Engineering

# Outline

- **Background**
  - **How loudspeakers work**
  - **Waveforms**
  - **Wavelengths**
  - **Speed of sound**
  - **How sound propagates**
  - **Sound pressure level (dB)**
  - **Summation of audio signals**
  - **Phase wheel**
  - **Beamwidth**
  - **3D directivity “balloons”**

# How Loudspeakers Work

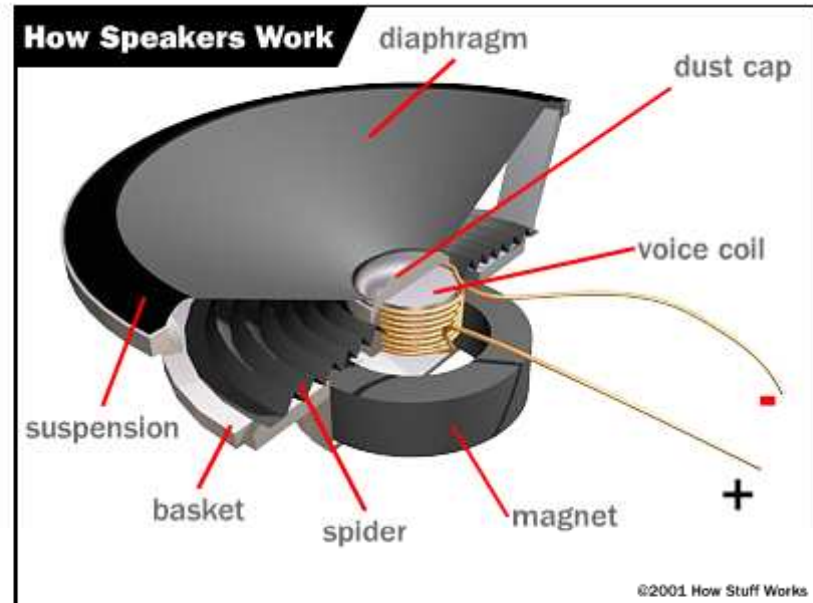
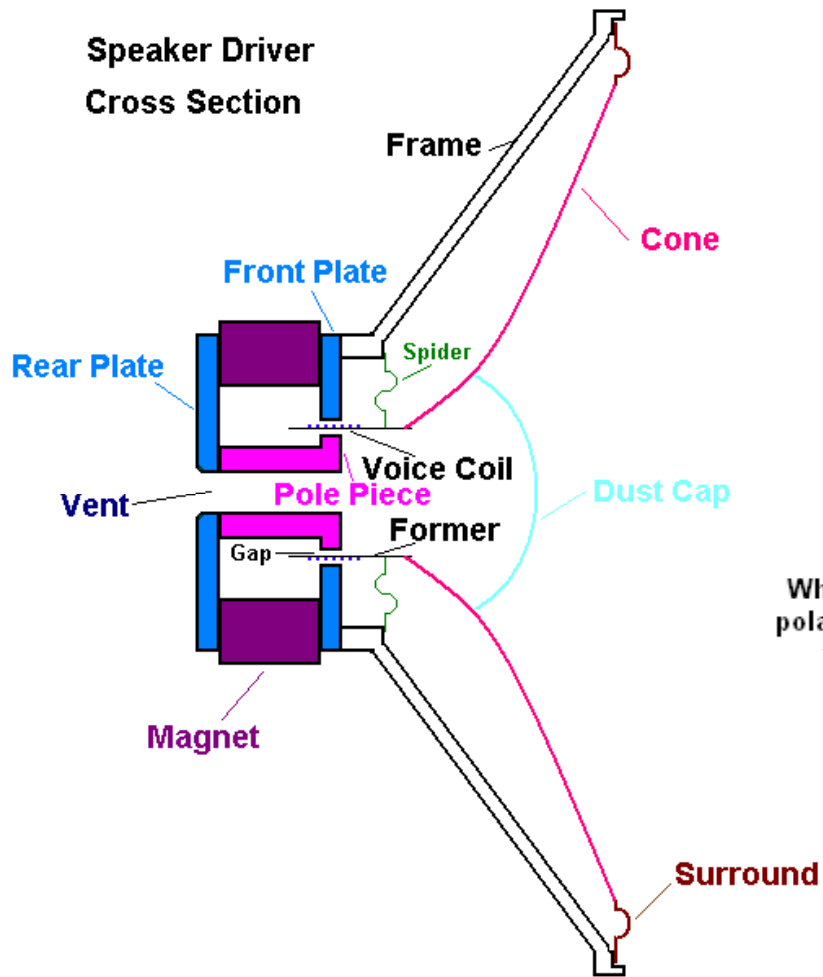

When the electrical current flowing through the voice coil changes direction, the coil's polar orientation reverses. This changes the magnetic forces between the voice coil and the permanent magnet, moving the coil and attached diaphragm back and forth.

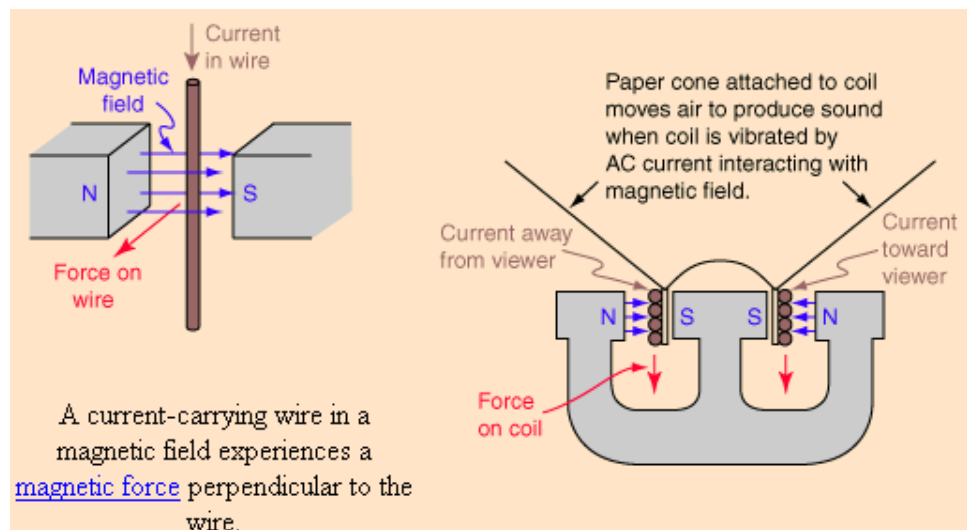

# How Loudspeakers Are Made

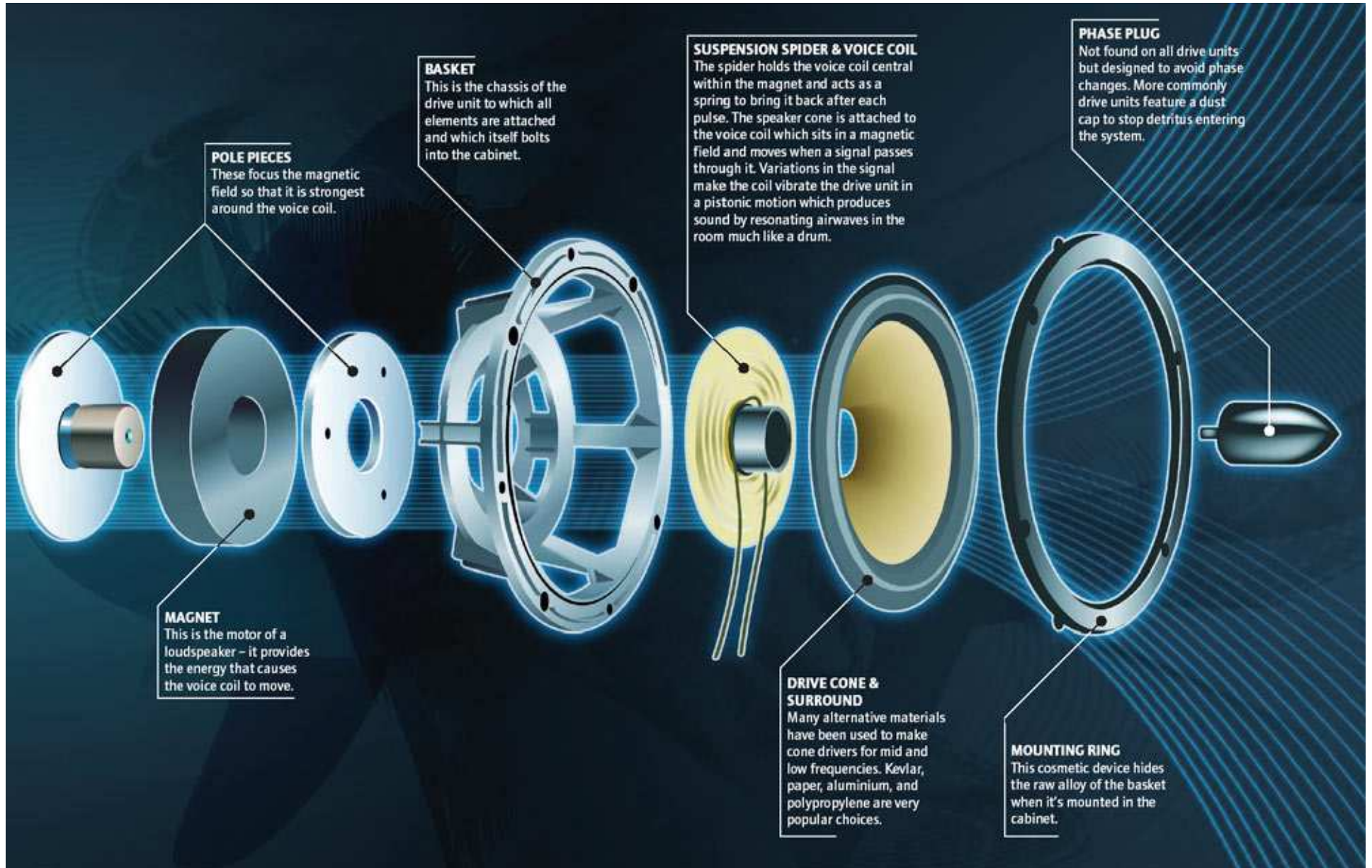

# The Waveform

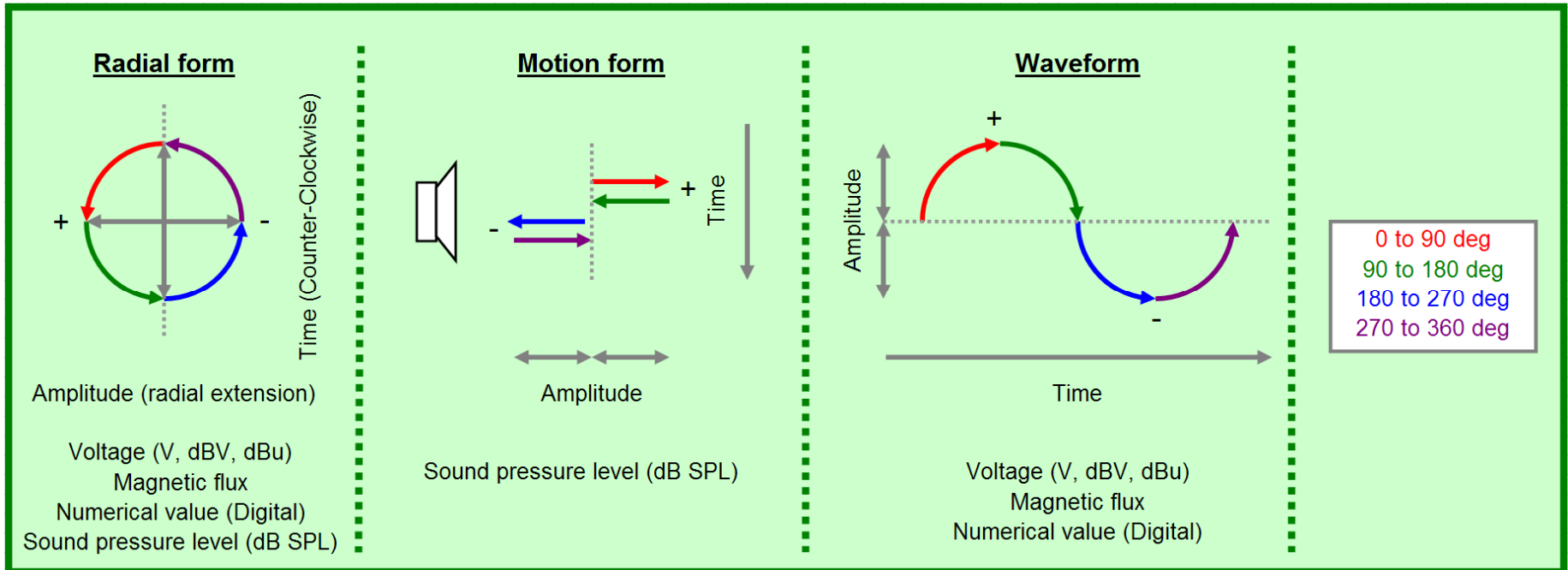

## Wavelength Reference Chart

Frequency (Hz)	Period (ms)	Wavelength (Room temp)		Comparable size
		(m)	(ft)	
20	50.00	17.24	56.56	
25	40.00	13.79	45.07	Intermodal shipping container
32	31.75	10.94	35.77	
40	25.00	8.62	28.17	Band gear truck length
50	20.00	6.90	22.54	1/2 size intermodal container
63	15.87	5.47	17.89	Gas guzzling SUV length
80	12.50	4.31	14.09	Full Size car length
100	10.00	3.45	11.27	Compact car length
125	8.00	2.76	9.01	Too wide for the truck
160	6.25	2.15	7.04	Shaquille O'Neal
200	5.00	1.72	5.63	Average height
250	4.00	1.38	4.51	Shoulder Height
315	3.17	1.09	3.58	
400	2.50	0.86	2.82	
500	2.00	0.69	2.25	Arm's length
630	1.59	0.55	1.79	
800	1.25	0.43	1.41	
1,000	1.00	0.34	1.13	Elbow to fist
1,250	0.80	0.28	0.90	Man's foot
1,600	0.63	0.22	0.70	Woman's foot
2,000	0.50	0.17	0.56	Eight fingers
2,500	0.40	0.14	0.45	
3,150	0.32	0.11	0.36	CD/DVD
4,000	0.25	0.086	0.28	Four fingers
5,000	0.20	0.069	0.23	
6,300	0.16	0.055	0.18	
8,000	0.13	0.043	0.14	Two fingers
10,000	0.10	0.034	0.11	
12,500	0.08	0.028	0.09	
16,000	0.06	0.022	0.07	One finger
20,000	0.05	0.017	0.06	

$$\lambda = C/F$$

C is speed  
of sound at  
ambient  
conditions

## Temperature Effects on Speed of Sound

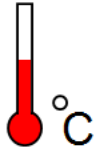
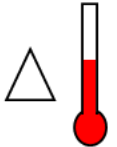
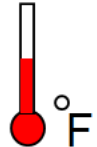
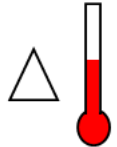
 <b>C</b> Speed of sound		 <b>ΔC</b>		 <b>C</b> Speed of sound		
Metric		Temperature change	Speed of Sound Change	English		Temperature change
Temperature Degrees (C)	Speed m/sec	Degrees (C)	(%)	Temperature Degrees (F)	Speed (ft/sec)	Degrees (F)
0.0	331.4	-22.2	3.9%	32	1087.2	-40.0
1.1	332.1	-21.1	3.7%	34	1089.4	-38.0
2.2	332.7	-20.0	3.5%	36	1091.6	-36.0
3.3	333.4	-18.9	3.3%	38	1093.8	-34.0
4.4	334.1	-17.8	3.1%	40	1096.0	-32.0
5.6	334.8	-16.7	2.9%	42	1098.2	-30.0
6.7	335.4	-15.6	2.7%	44	1100.4	-28.0
7.8	336.1	-14.4	2.5%	46	1102.6	-26.0
8.9	336.8	-13.3	2.3%	48	1104.8	-24.0
10.0	337.5	-12.2	2.2%	50	1107.0	-22.0
11.1	338.1	-11.1	2.0%	52	1109.2	-20.0
12.2	338.8	-10.0	1.8%	54	1111.4	-18.0
13.3	339.5	-8.9	1.6%	56	1113.6	-16.0
14.4	340.2	-7.8	1.4%	58	1115.8	-14.0
15.6	340.8	-6.7	1.2%	60	1118.0	-12.0
16.7	341.5	-5.6	1.0%	62	1120.2	-10.0
17.8	342.2	-4.4	0.8%	64	1122.4	-8.0
18.9	342.9	-3.3	0.6%	66	1124.6	-6.0
20.0	343.5	-2.2	0.4%	68	1126.8	-4.0
21.1	344.2	-1.1	0.2%	70	1129.0	-2.0
22.2	344.9	0.0	0.0%	72	1131.2	0.0
23.3	345.6	1.1	-0.2%	74	1133.4	2.0
24.4	346.2	2.2	-0.4%	76	1135.6	4.0
25.6	346.9	3.3	-0.6%	78	1137.8	6.0
26.7	347.6	4.4	-0.8%	80	1140.0	8.0
27.8	348.3	5.6	-1.0%	82	1142.2	10.0
28.9	348.9	6.7	-1.2%	84	1144.4	12.0
30.0	349.6	7.8	-1.4%	86	1146.6	14.0
31.1	350.3	8.9	-1.6%	88	1148.8	16.0
32.2	351.0	10.0	-1.8%	90	1151.0	18.0
33.3	351.6	11.1	-2.0%	92	1153.2	20.0
34.4	352.3	12.2	-2.2%	94	1155.4	22.0
35.6	353.0	13.3	-2.3%	96	1157.6	24.0
36.7	353.7	14.4	-2.5%	98	1159.8	26.0
37.8	354.3	15.6	-2.7%	100	1162.0	28.0

# How Sound Propagates

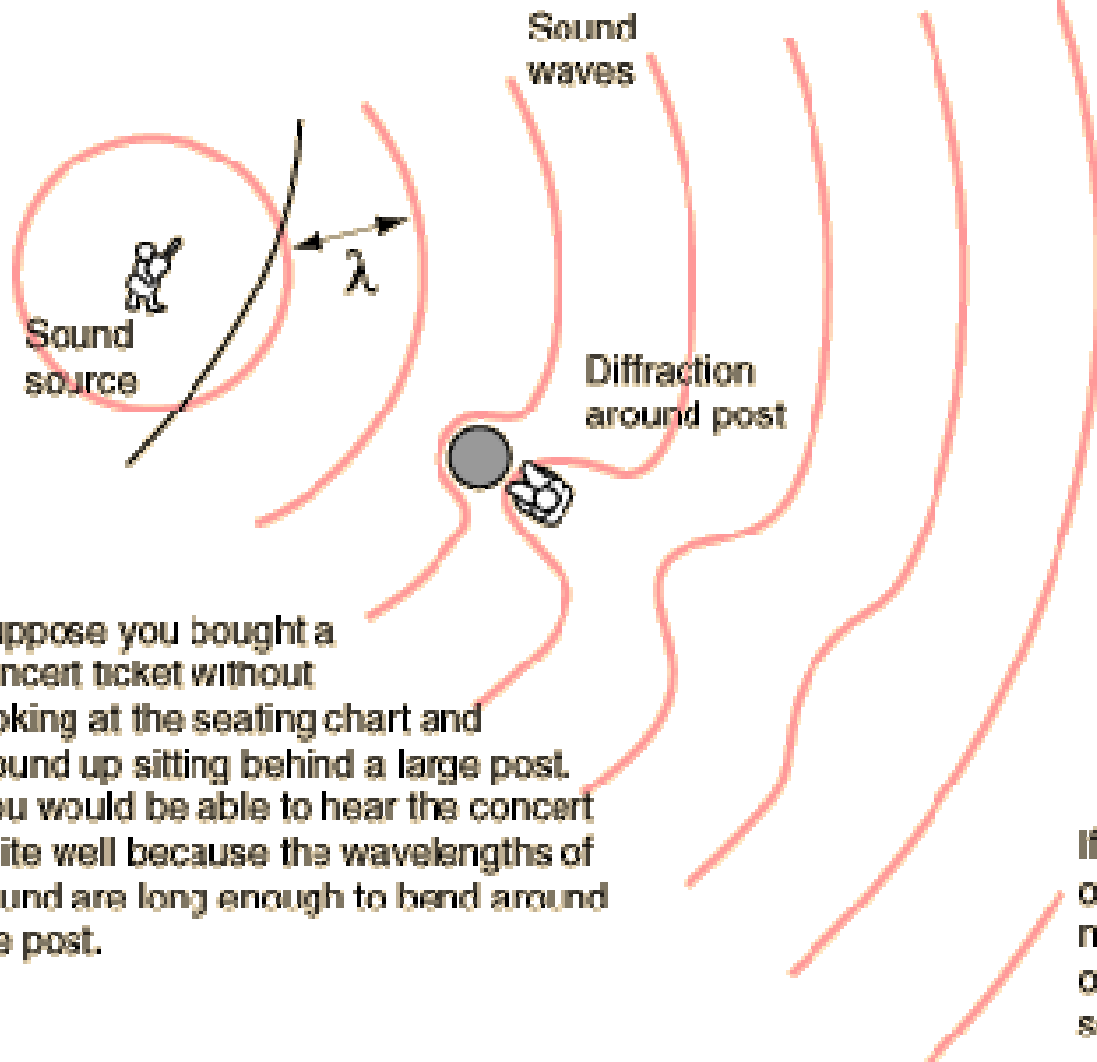

Suppose you bought a concert ticket without looking at the seating chart and wound up sitting behind a large post. You would be able to hear the concert quite well because the wavelengths of sound are long enough to bend around the post.

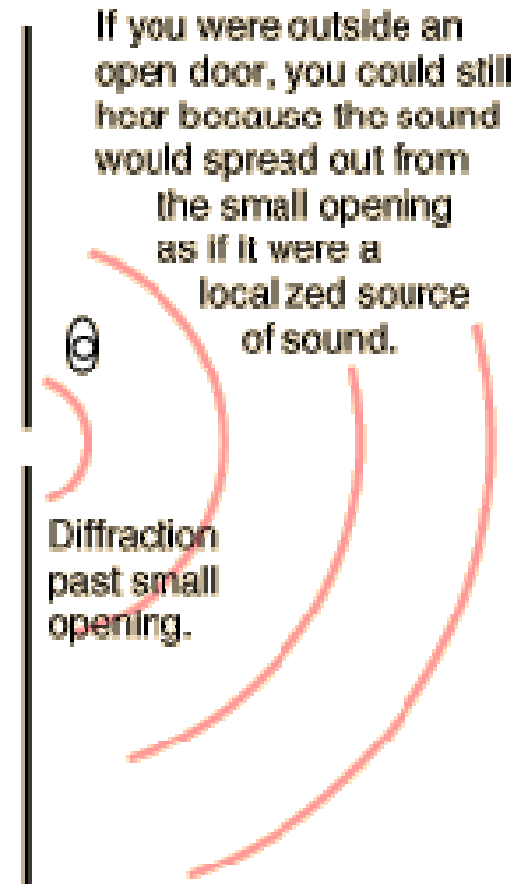

If you were several wavelengths of sound past the post, you would not be able to detect the presence of the post from the nature of the sound.

# Acoustic Decibel (dB SPL)

- In acoustics, the ratios most commonly encountered are changes in pressure level, measured in dB-SPL:

$$\text{dB-SPL} = 20 \log_{10}(p/p_0) \text{ where } p_0 = 20 \mu\text{N/m}^2$$

- As distance from a sound source **doubles**, the dB-SPL decreases **6 dB** (this is called **the inverse square law**)
- Adding/subtracting dB levels:  
$$\text{SPLa} \pm \text{SPLb} = 10 \log_{10} [ 10^{\text{db-SPLa}/10} \pm 10^{\text{db-SPLb}/10} ]$$
- **Doubling acoustic power** corresponds to a **3 dB** increase in SPL
- **Doubling perceived loudness** corresponds to a **10 dB** increase in SPL

## Acoustic Transmission: Inverse Square Law

6 dB loss per doubling distance is constant in free field omnidirectional and directional propagation

Omnidirectional propagation

Directional propagation

**Note:** 3 dB/color

Distance unit

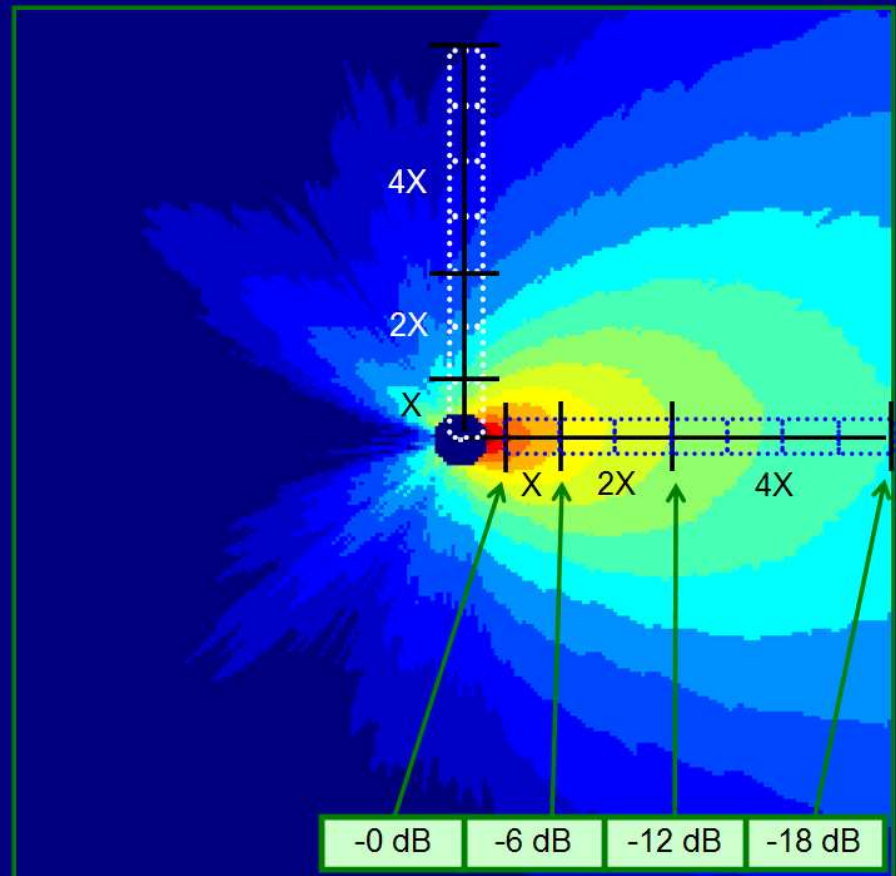
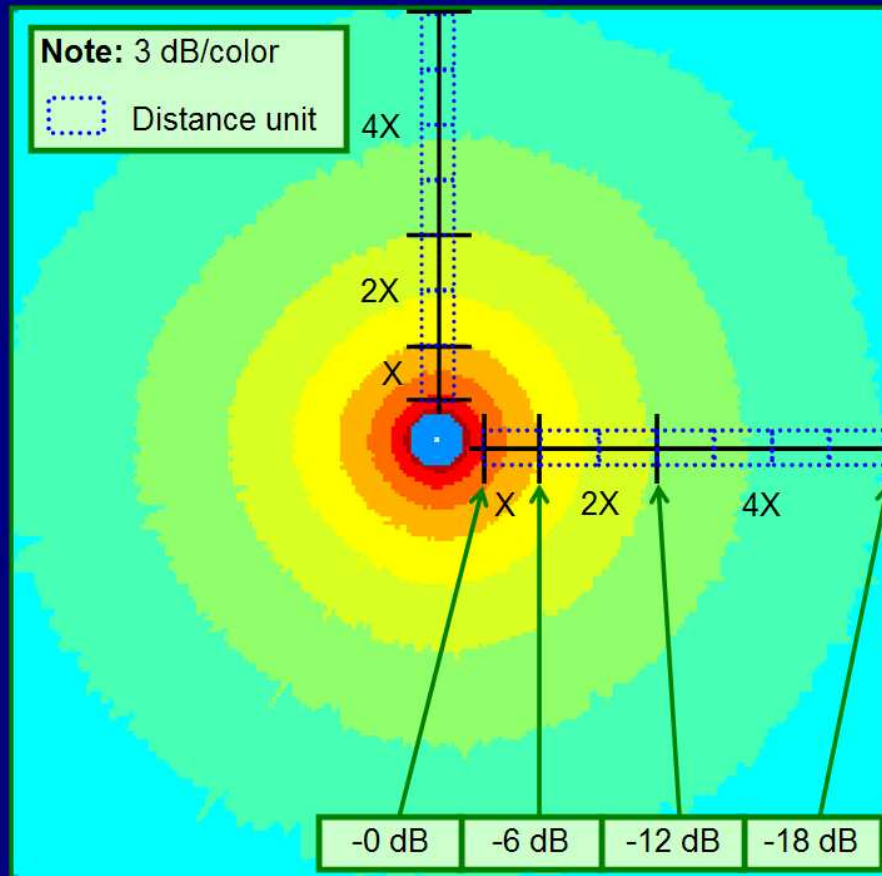

Relative level is equal in all directions over distance.  
Doubling distance loss is equal in all directions.

Relative level is not equal due to directional control.  
Doubling distance loss is equal in all directions.

## Decibel Ratio Reference

Decibel Ratio Reference			
20 x log (Level <sub>1</sub> /Level <sub>2</sub> )		10 x log (Power <sub>1</sub> /Power <sub>2</sub> )	
Pressure (SPL)			
Voltage (V)		Power (P)	
Current (I)			
Value (dB)	Ratio (L <sub>1</sub> /L <sub>2</sub> )	Value (dB)	Ratio (P <sub>1</sub> /P <sub>2</sub> )
0.0	1.00	0.0	1.00
1.0	1.12	0.5	1.12
2.0	1.26	1.0	1.26
3.0	1.41	1.5	1.41
4.0	1.59	2.0	1.59
5.0	1.78	2.5	1.78
6.0	2.00	3.0	2.00
7.0	2.24	3.5	2.24
8.0	2.51	4.0	2.51
9.0	2.82	4.5	2.82
10	3.16	5.0	3.16
12	4.00	6.0	4.00
14	5.00	7.0	5.00
15	5.63	7.5	5.66
18	8.00	9.0	8.00
20	10	10	10
26	20	13	20
32	40	16	40
38	80	19	80
40	100	20	100
60	1,000	30	1,000
80	10,000	40	10,000
100	100,000	50	100,000

## Crest Factor: Peak to RMS Ratio

The relationship of RMS, peak and peak to peak values to the audio waveform

Normalized to Peak Value

+ Peak Value 1.0

RMS Value 0.707

0.0

- Peak Value -1.0

Crest Factor = 3 dB (1.414:1)

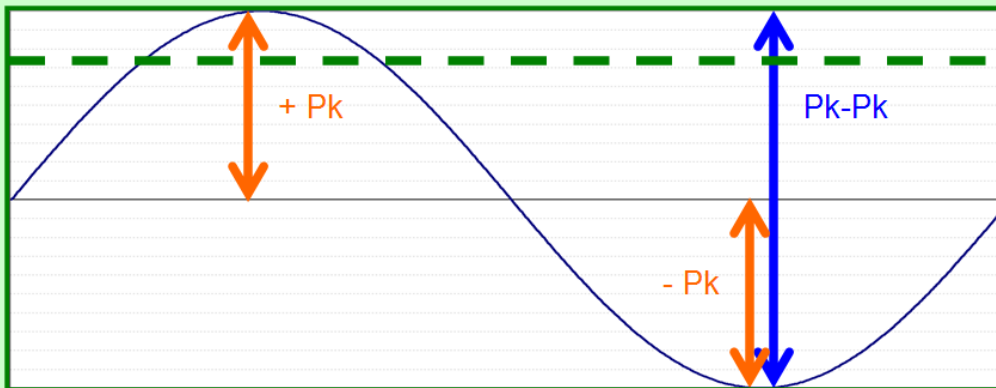

Normalized to RMS Value

1.414 + Peak Value

1.0 RMS Value

0.0

-1.414 - Peak Value

Normalized to Peak Value

+ Peak Value 1.0

RMS Value 0.25

0.0

- Peak Value -1.0

Crest Factor = 12 dB (4:1)

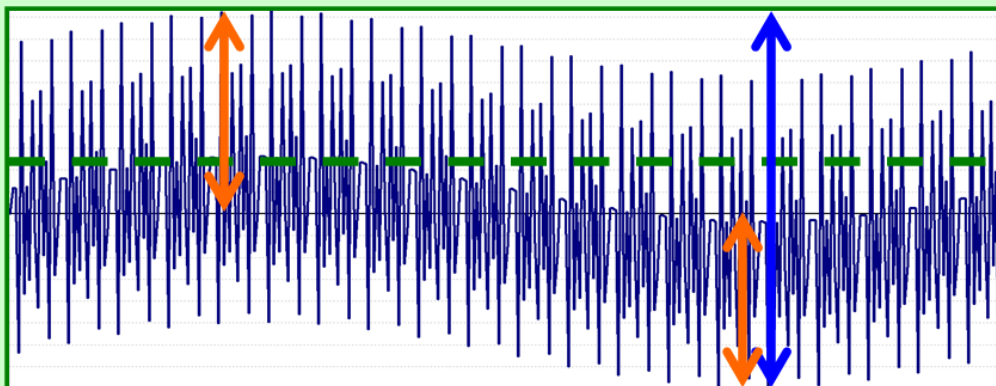

Normalized to RMS Value

4.0 + Peak Value

1.0 RMS Value

0.0

-4.0 - Peak Value

dB SPL Operating Levels						
Listening Level		Ear Level	Comments	High Level	Medium Level	Low Level
dB SPL	dB SPL Pk	Range		Music	Music	Music
133.0	145.0					
130.0	142.0		Pain Threshold			
127.0	139.0					
124.0	136.0					
121.0	133.0		Non-Linear region			
118.0	130.0					
115.0	127.0					
112.0	124.0					
109.0	121.0		High Level Music			
106.0	118.0					
103.0	115.0			X		
100.0	112.0					
97.0	109.0		Medium Level Music			
94.0	106.0					
91.0	103.0				X	
88.0	100.0					
85.0	97.0		Low Level Music			
82.0	94.0					
79.0	91.0					X
76.0	88.0					
73.0	85.0					
70.0	82.0					
67.0	79.0		Speech at .5 meters			
64.0	76.0					
61.0	73.0		Speech at 1 meter			
58.0	70.0		Noisy HVAC			
55.0	67.0		Speech at 2 meters			
52.0	64.0					
49.0	61.0		Typical HVAC			
46.0	58.0					
43.0	55.0					
40.0	52.0		Quiet Room			
37.0	49.0					
34.0	46.0		VERY quiet room			
31.0	43.0					
28.0	40.0					
25.0	37.0					
22.0	34.0		Recording Studio			
19.0	31.0					
16.0	28.0					
13.0	25.0		Dream on!			
10.0	22.0					
7.0	19.0					
4.0	16.0		Brownian motion			
1.0	13.0		Noise floor of air			
-2.0	10.0		and ear			
-5.0	7.0					
-8.0	4.0					
-11.0	1.0					

# Electrical Power Requirement

- When SPL goal at a given listening distance known, also need:
  - Sensitivity rating of loudspeaker (typically spec as **1m** on-axis with input of **1 electrical watt**)
  - Acoustic level change/attenuation between loudspeaker and farthest listening position
- Example: **90 dB** program level at listening distance of **32 m outdoors**
  - Loudspeaker sensitivity measured as **110 dB**
  - **Acoustic level change** =  $20 \log (32) \cong 30 \text{ dB}$
  - Add **10 dB** for peak (program level) headroom
  - SPL required at source is  $90 + 30 + 10 = 130 \text{ dB}$
  - Need **20 dB** above 1 watt, or  $10^{(20/10)} = 100 \text{ W}$

# Stable Summation Criteria

1. Must have matched origin
2. May contain unlimited multiple inputs
3. May arrive from different directions
4. Must have significant overlap duration

# Summation Criteria: Matched Origin

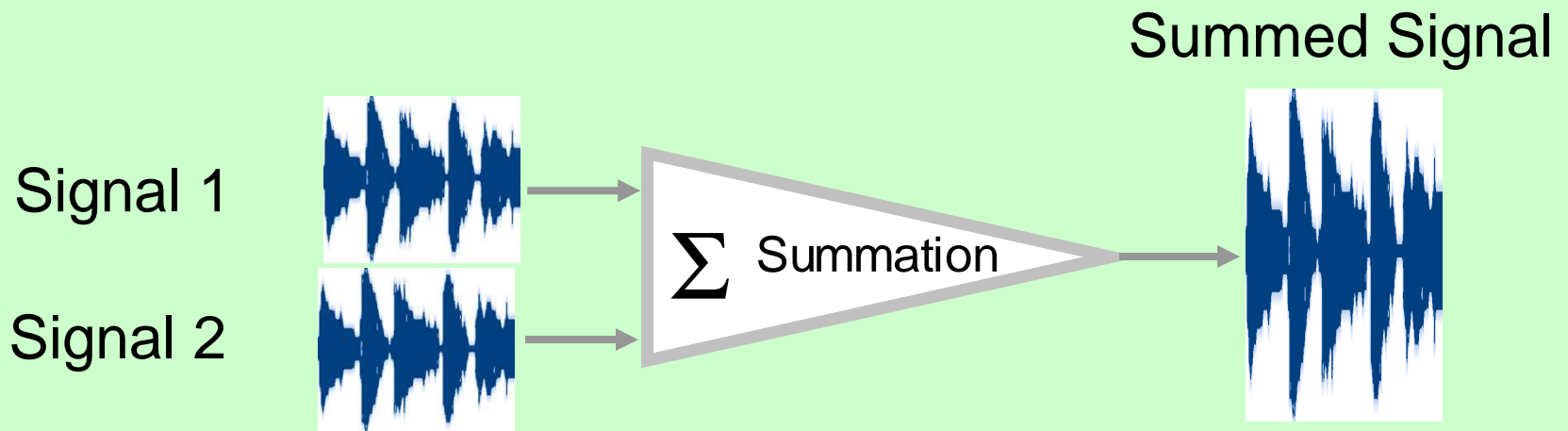
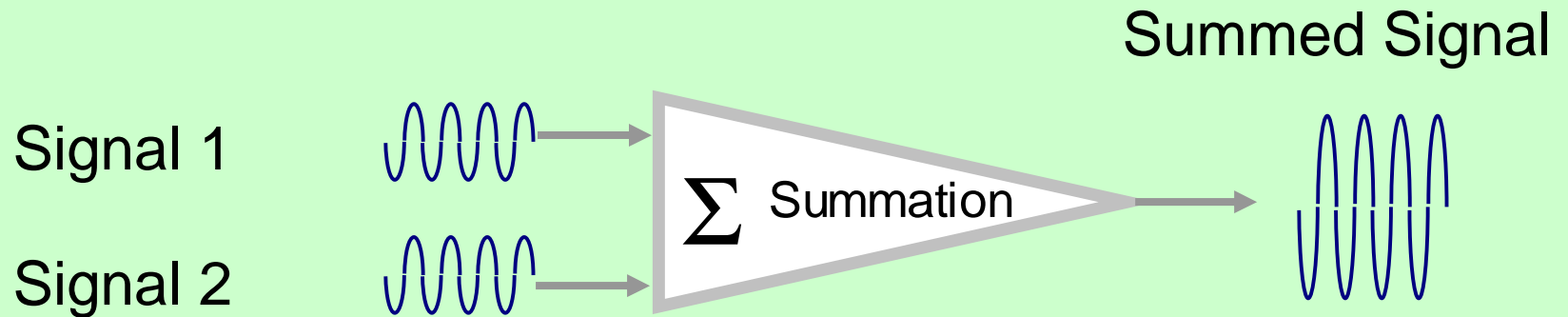

# Summation Criteria: Matched Origin

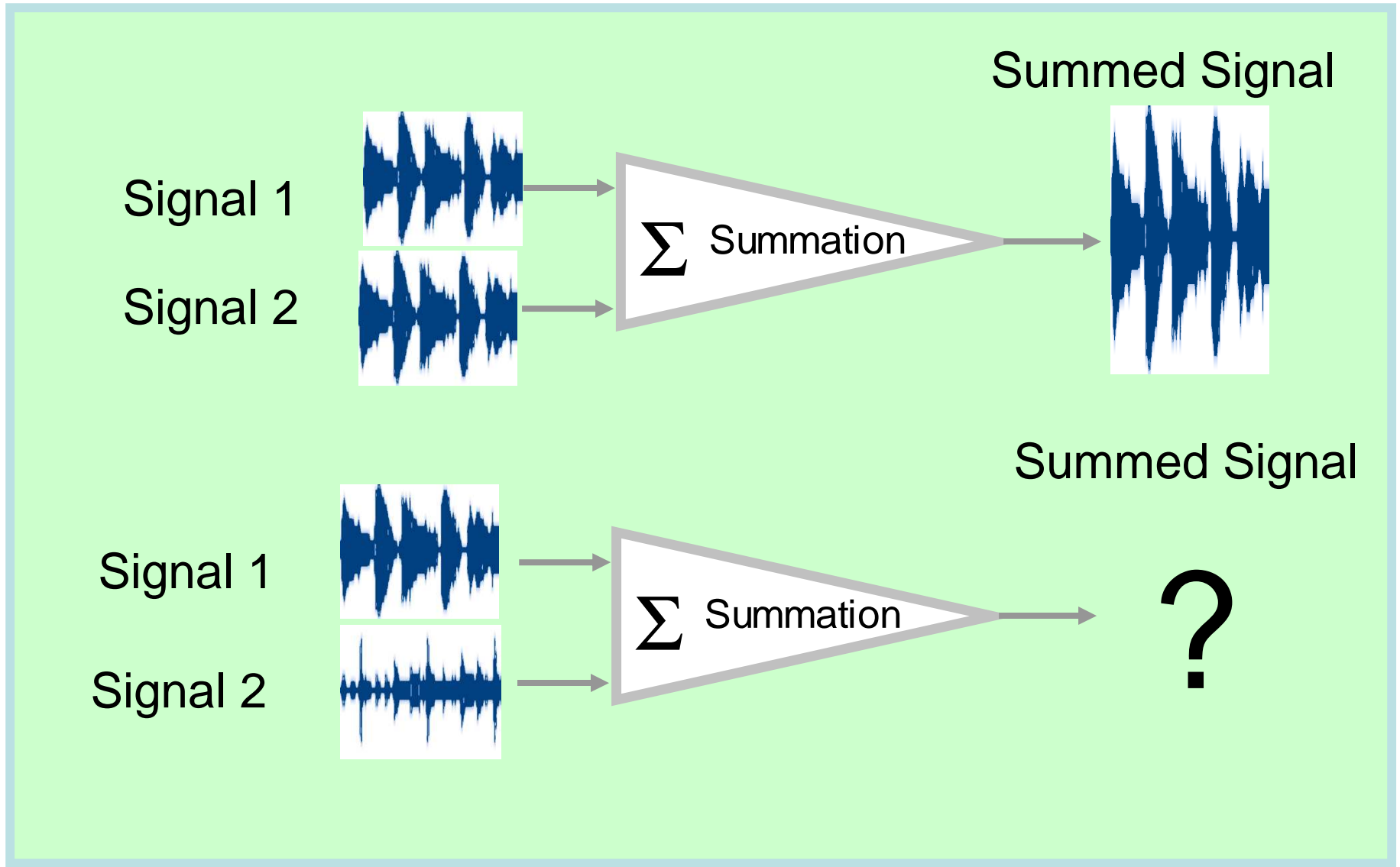

# Summation Criteria: Multiple Input Signals

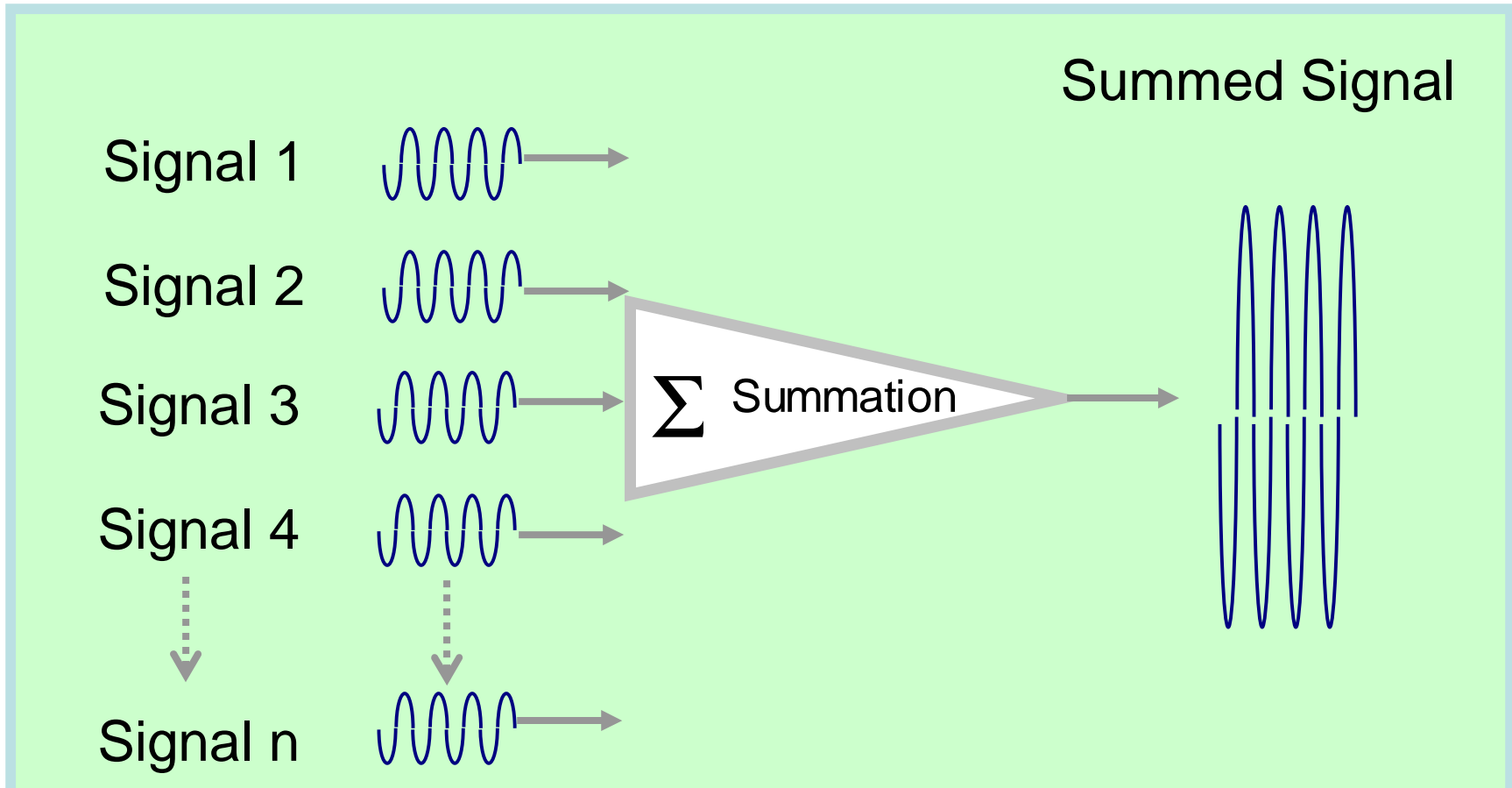

Multiple Input Summation Level Reference												
# of Inputs	2	3	4	5	6	8	10	12	16	20	24	32
Level relative to single input	+6 dB	+10 dB	+12 dB	+14 dB	+17 dB	+18 dB	+20 dB	+22 dB	+24 dB	+26 dB	+28 dB	+30 dB
Note: This is the <b>maximum</b> addition and will only occur when all inputs at matched level and phase												

# Summation Criteria: Input Signal Direction

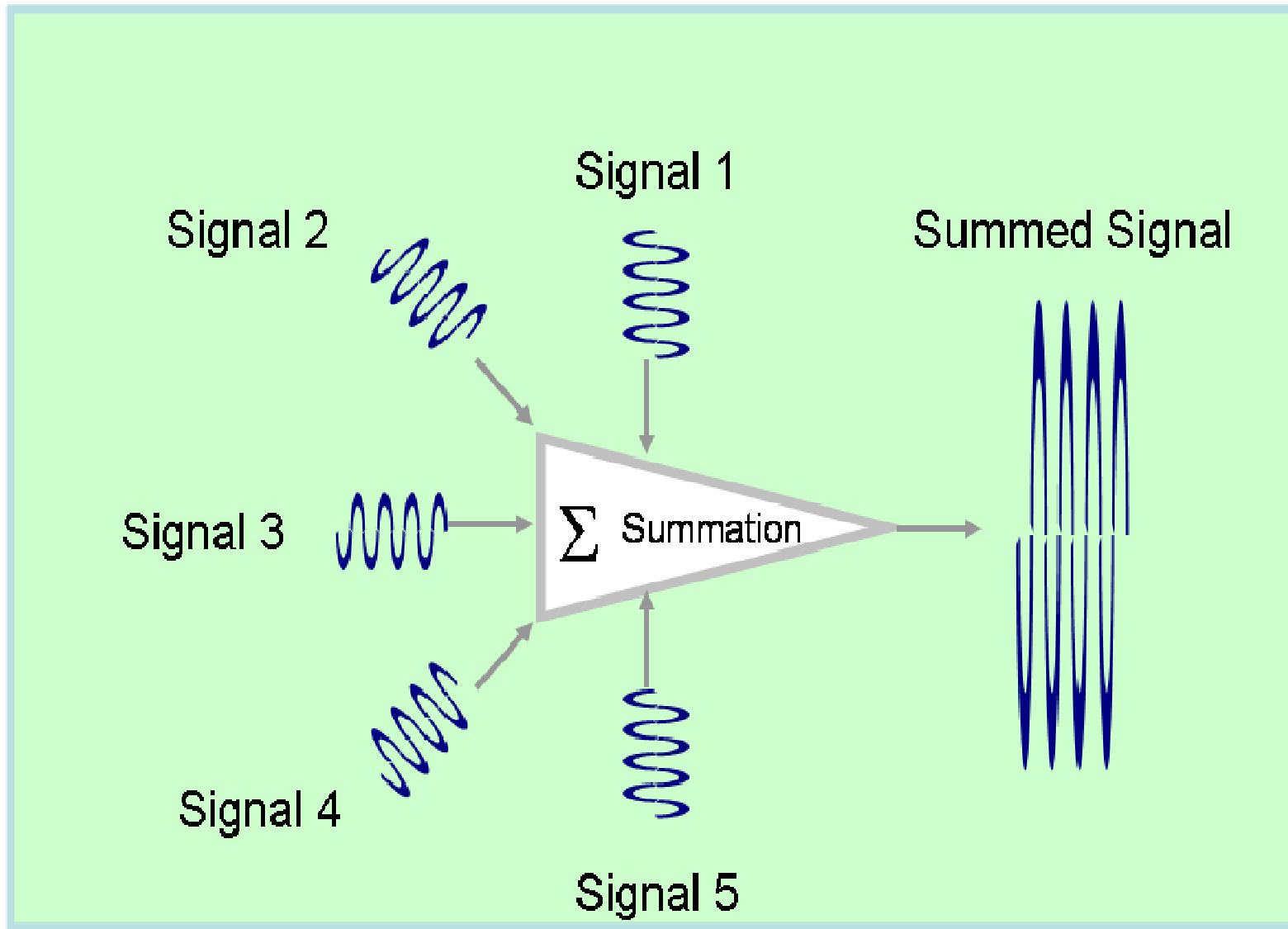

# Summation Criteria: Overlap Duration

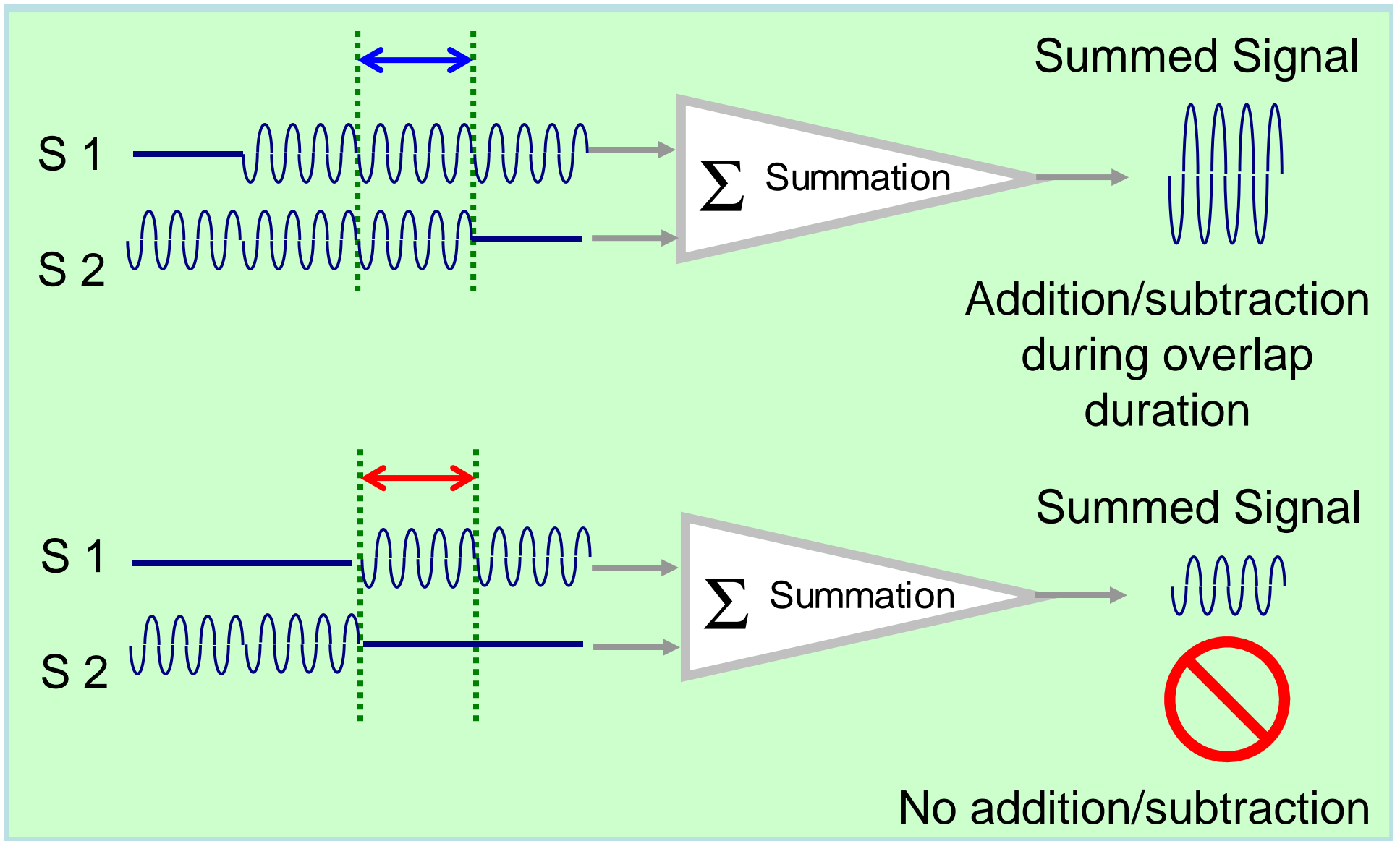

# Adding dB-SPL

Two acoustic sources “a” and “b” of relative phase angles  $\theta_a$  and  $\theta_b$

$$\begin{aligned} \Sigma_{\text{dB-SPL a+b}} = & \\ & 20 \log_{10} \left[ \text{sqrt} \left\{ \left( 10^{\text{dB-SPL a}/20} \right)^2 + \left( 10^{\text{dB-SPL b}/20} \right)^2 \right. \right. \\ & \left. \left. + 2 \left( 10^{\text{dB-SPL a}/20} \right) \left( 10^{\text{dB-SPL b}/20} \right) \left( \cos(\theta_a - \theta_b) \right) \right\} \right] \end{aligned}$$

# Adding dB-SPL – “Simplifications”

If both sources are **in phase** and only the relative level varies (where source “a” is **0 dB**, simplifies to:

$$\sum_{\text{dB-SPL}} a+b = 20 \log_{10} \left[ 1 + 10^{\text{dB-SPL}b/20} \right]$$

If both sources are at 0 dB and phase angle  $\theta_a = 0$  (i.e., same level, only relative phase angle varies), simplifies to :

$$\sum_{\text{dB-SPL}} a+b = 20 \log_{10} \left[ \text{sqrt} \{ 2 + 2\cos(-\theta_b) \} \right]$$

## Relative Level Effects on Two Input Summation (Matched sources with 0 degrees relative phase)

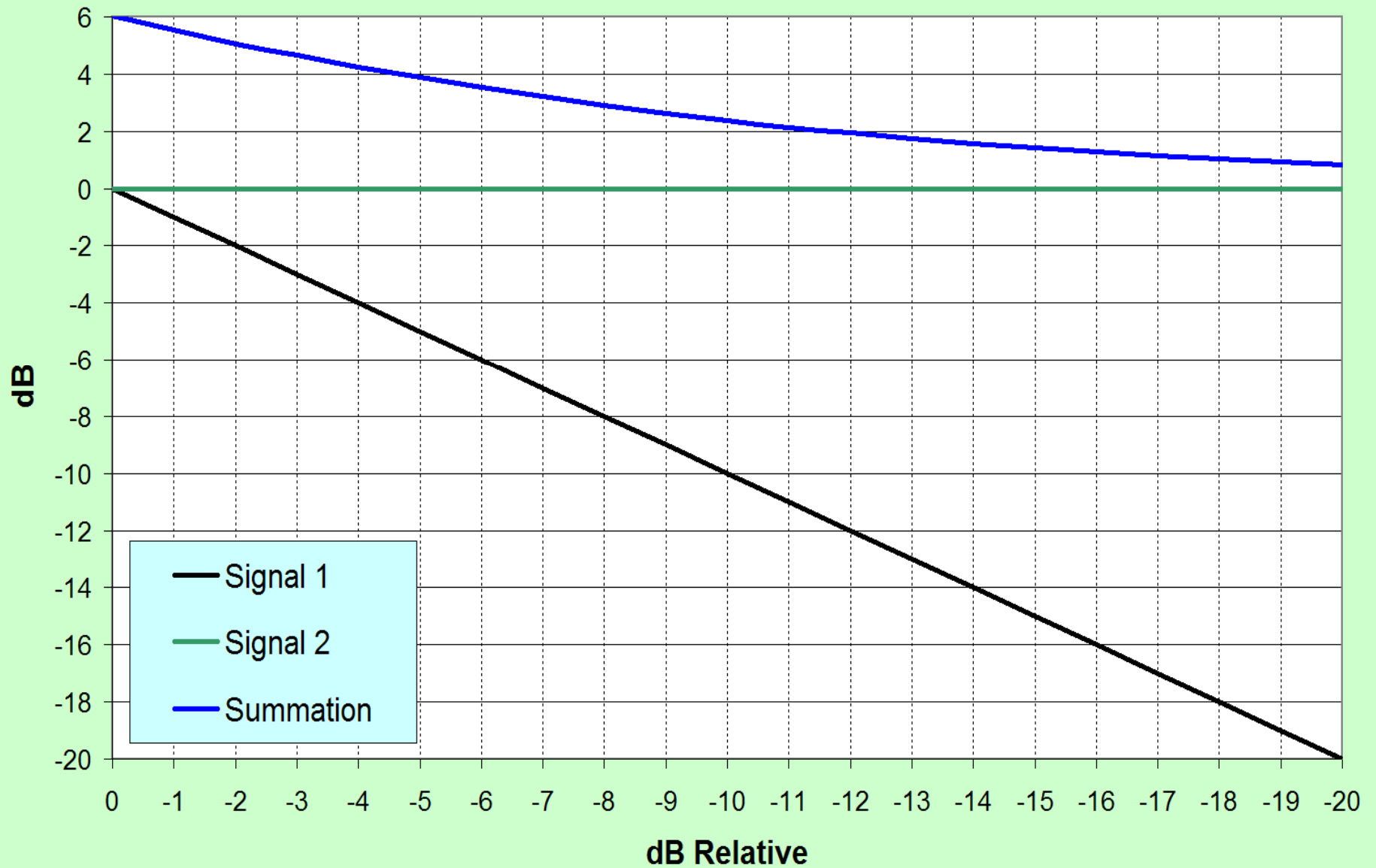

# Acoustic Addition & Subtraction: The Phase Wheel

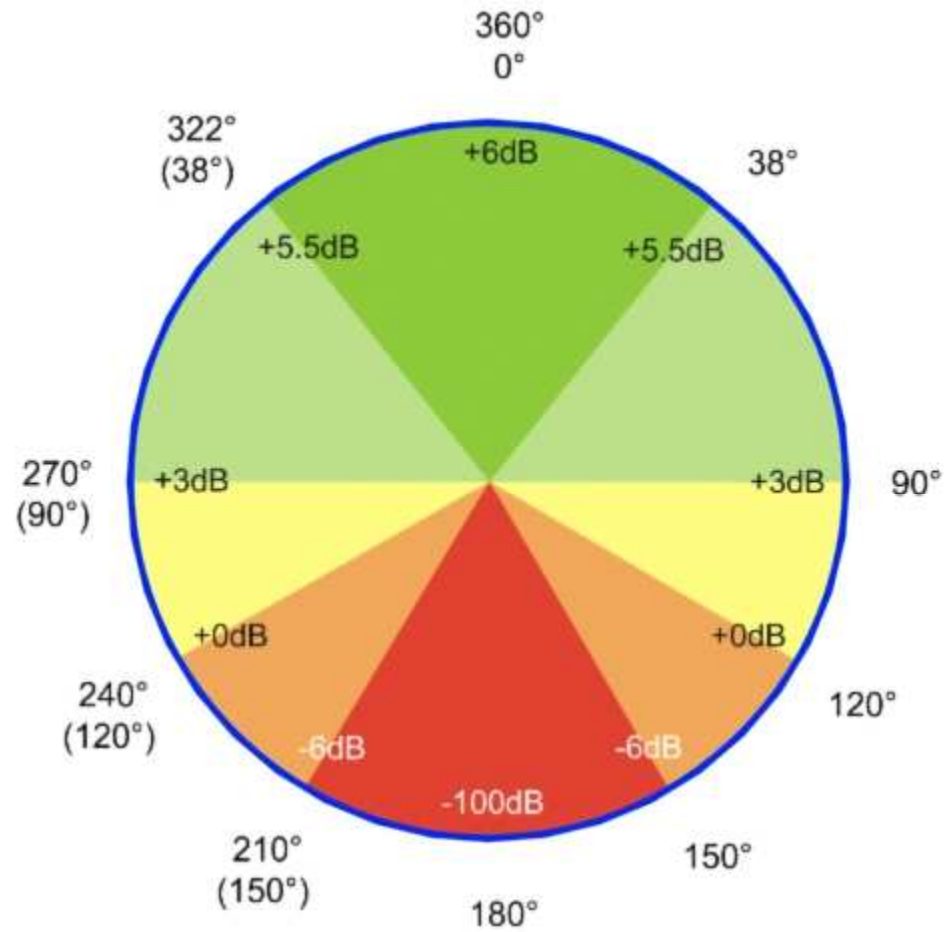

two identical signals summed at same level

## Acoustic Addition & Subtraction: Level vs. Phase

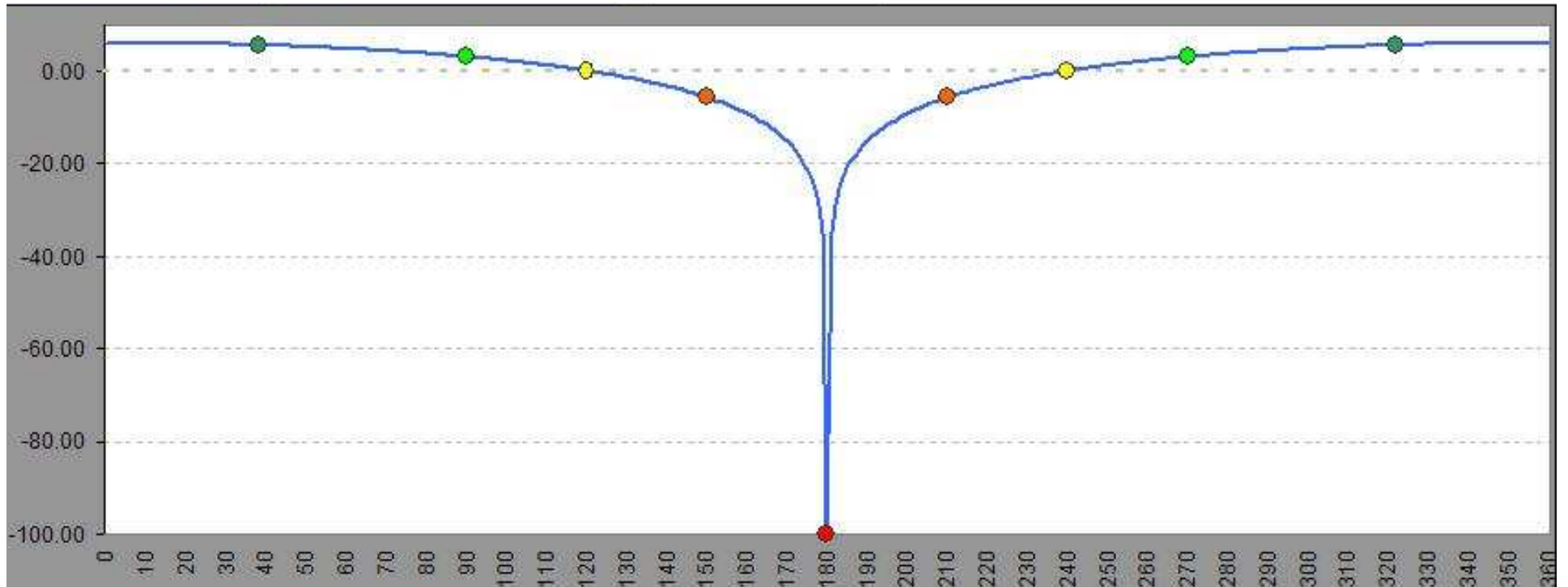

two identical signals summed at same level

# Factors Affecting Response at Summation Point

1. Level offset due to distance offset (inverse square law)
2. Level offset due to polar response (frequency dependent)
3. Phase offset due to path length difference

# Summation: Response Ripple

1. Time offsets shift all frequencies by the same amount of time
2. Time offsets shift all frequencies by a different amount of phase
3. Result of summation with time offset (of signals at same frequency) is **response ripple**

# Summation Zones Defined

- Coupling zone
  - Sources within  $\pm 1/3$  wavelength ( $\pm 120^\circ$ )
  - Amount of addition ranges for 0 to 6 dB depending on phase/level offset
  - Ripple is  $\pm 3$  dB
  - Most easily achieved at low frequencies due to large wavelengths

# Summation Zones Defined

- Cancellation zone
  - Effects only subtractive
  - Phase offset  $150^\circ$  to  $180^\circ$
  - Ripple  $\pm 50$  dB

# Summation Zones Defined

- Combing Zone
  - Phase offset reaches point where subtraction begins ( $> \pm 120^\circ$ )
  - Less than 4 dB level difference
  - Characterized by addition at some frequencies and dips at others
  - Ripple ranges from  $\pm 6$  dB to  $\pm 50$  dB
  - To be avoided – highest form of variance over frequency

# Summation Zones Defined

- Combining Zone
  - Level offset ranges from 4 dB to 10 dB
  - Semi-isolated state relative to sources, which limits the magnitude of addition/cancellation
  - Ripple no more than  $\pm 6$  dB

# Summation Zones Defined

- Isolation Zone
  - 10 dB or more of level offset
  - Relative interactions steadily reduced and eventually become negligible
  - At large level offset, relative phase has nominal effect
  - Ripple does not exceed 6 dB

# Properties of Summation: Time and level offset over frequency

Effects of 10 ms time offset between two signals that are unmatched in level over frequency

Amplitude  
(+/- 18 dB)



0 dB

**A**

Phase  
(+/- 180 deg)



0 ms

+

Amplitude  
(+/- 18 dB)

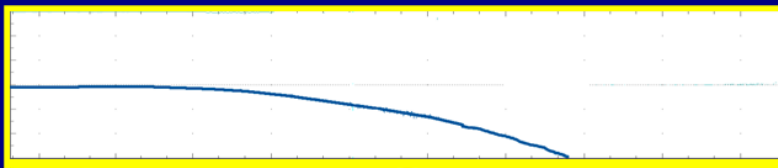

0 to -15 dB

**B**

Phase  
(+/- 180 deg)

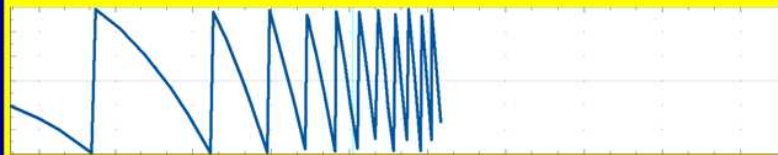

0 ms

Phase cycle turns at  
100 Hz rate

$\Sigma$

Amplitude  
(+/- 18 dB)

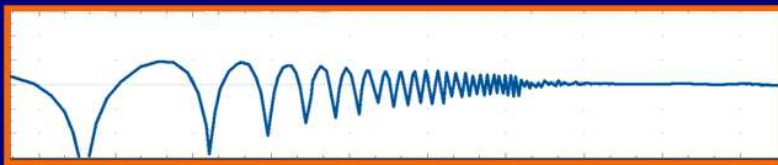

+6 to -60 dB

**A+B**

Phase  
(+/- 180 deg)

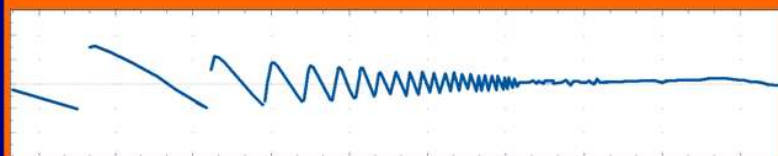

0 & 10 ms

### Summation Zones

- LF: Combing
- MF: Combining
- HF: Isolated

32 63 125 250 500 1k 2k 4k 8k 16kHz

# Acoustic Addition and Subtraction: Level Offset Effects

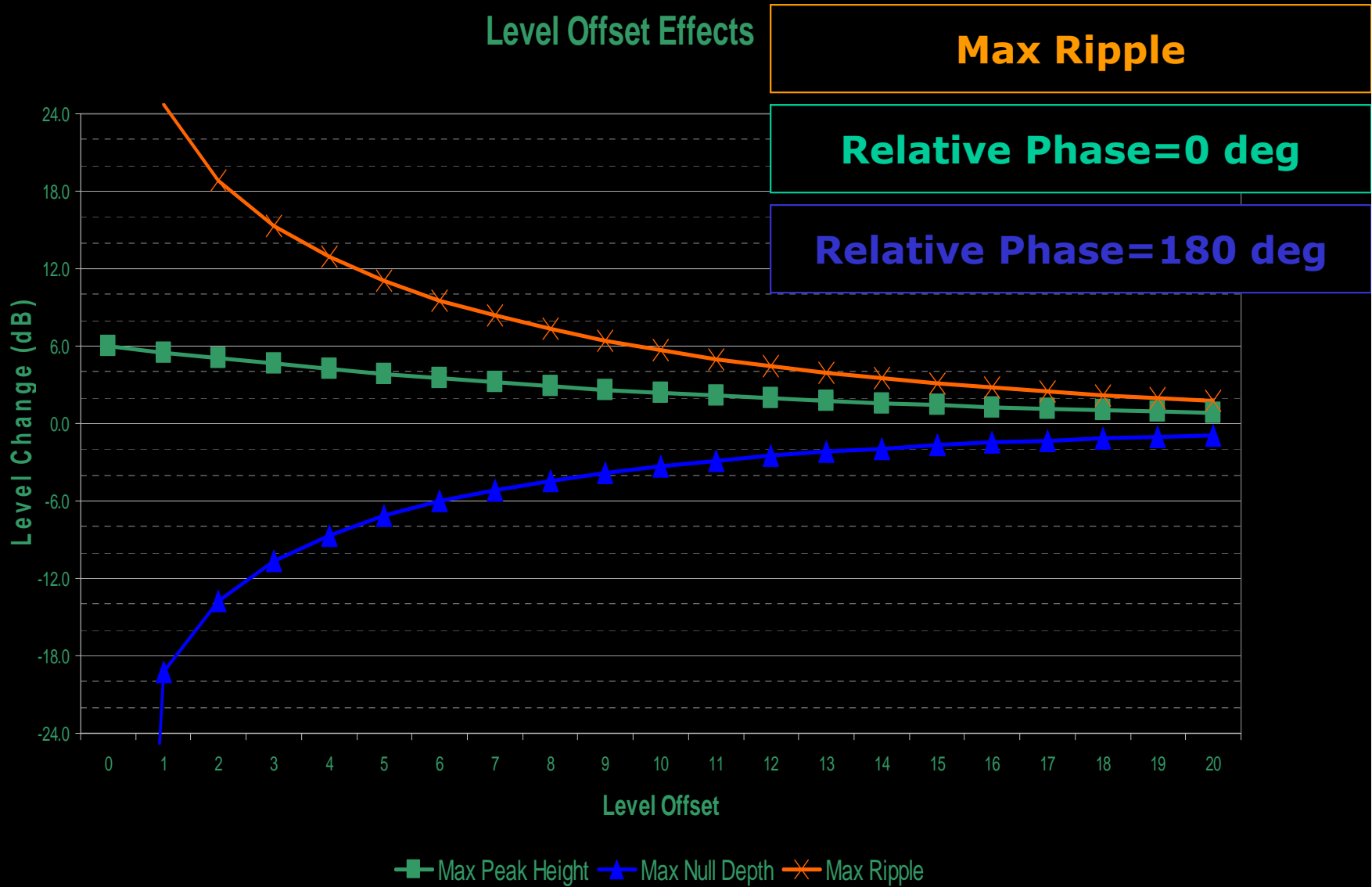

## Summation Zones: Icon Reference Chart

Summation Zone icon library with graphed with level and time offset relationships

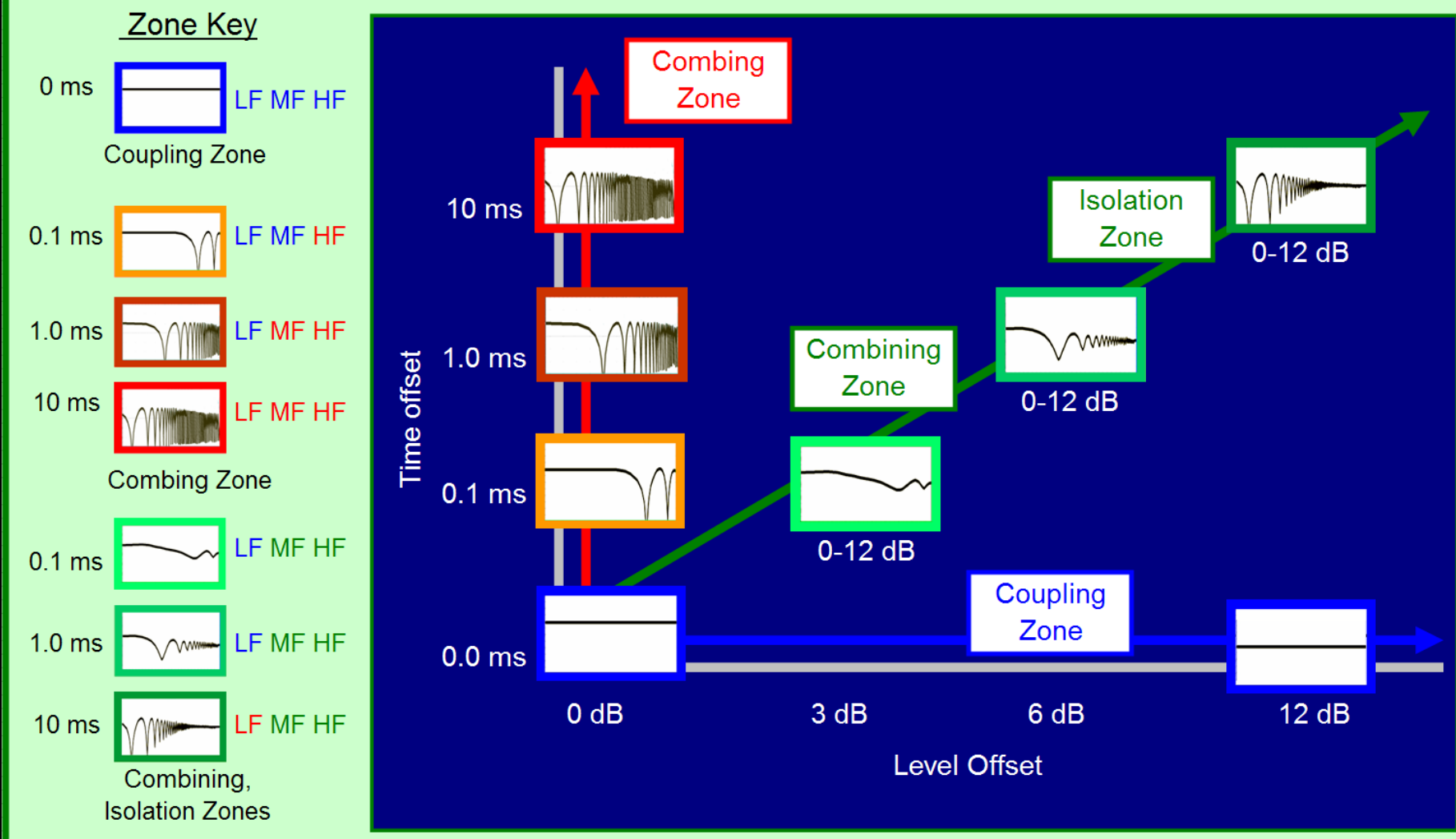

# Application

- loudspeaker mounted in a rigid (undamped) pipe 3 feet in length, open at one end, observed on-axis from “speaker end”



3 feet

# Application

- how does sound propagate at low frequencies?



3 feet

# Application

- how does sound propagate at low frequencies?

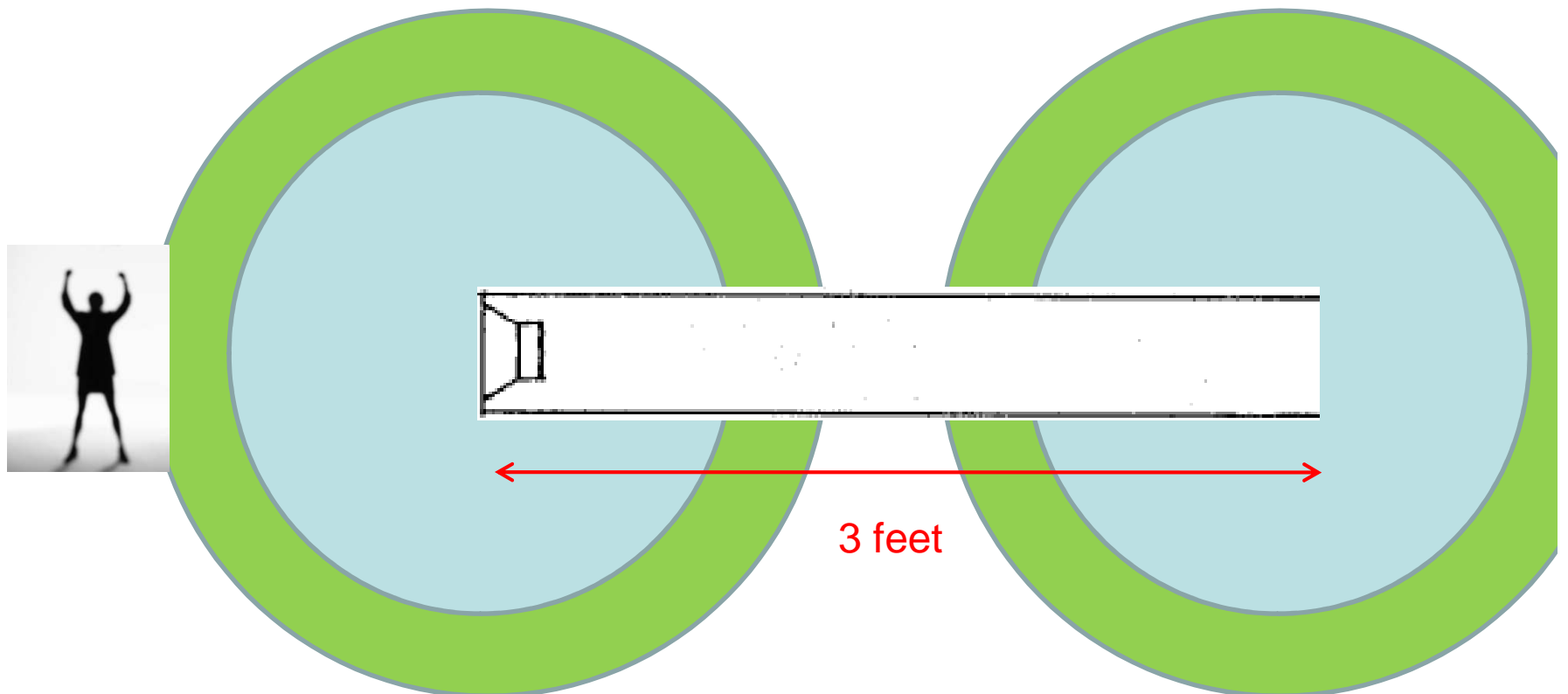

# Application

- if operated at 150 Hz, how much phase shift occurs as the wave traverses the pipe?

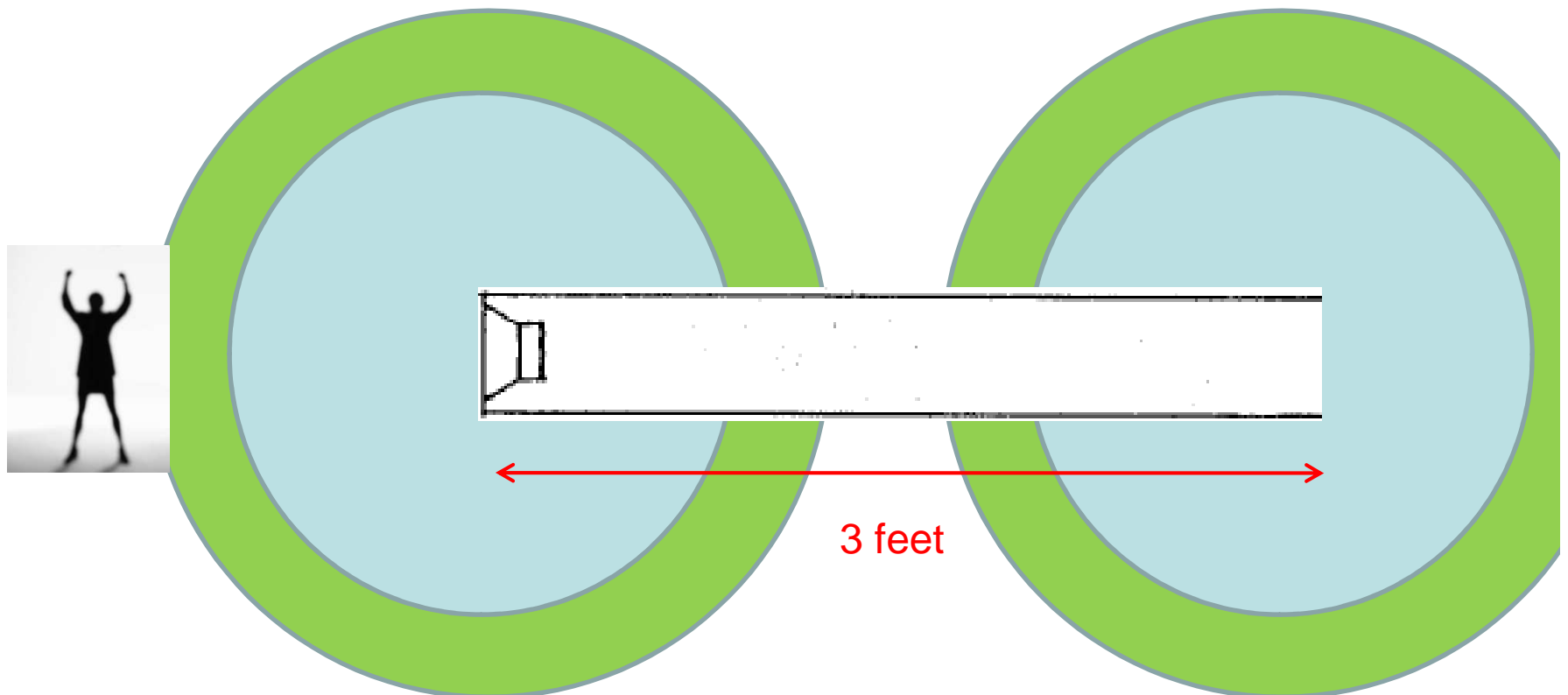

# Application

- if operated at 150 Hz, how much phase shift occurs as the wave traverses the pipe?

wavelength = 7.53 feet; phase shift =  $(360 \times 3) / 7.53$   
= 143 degrees

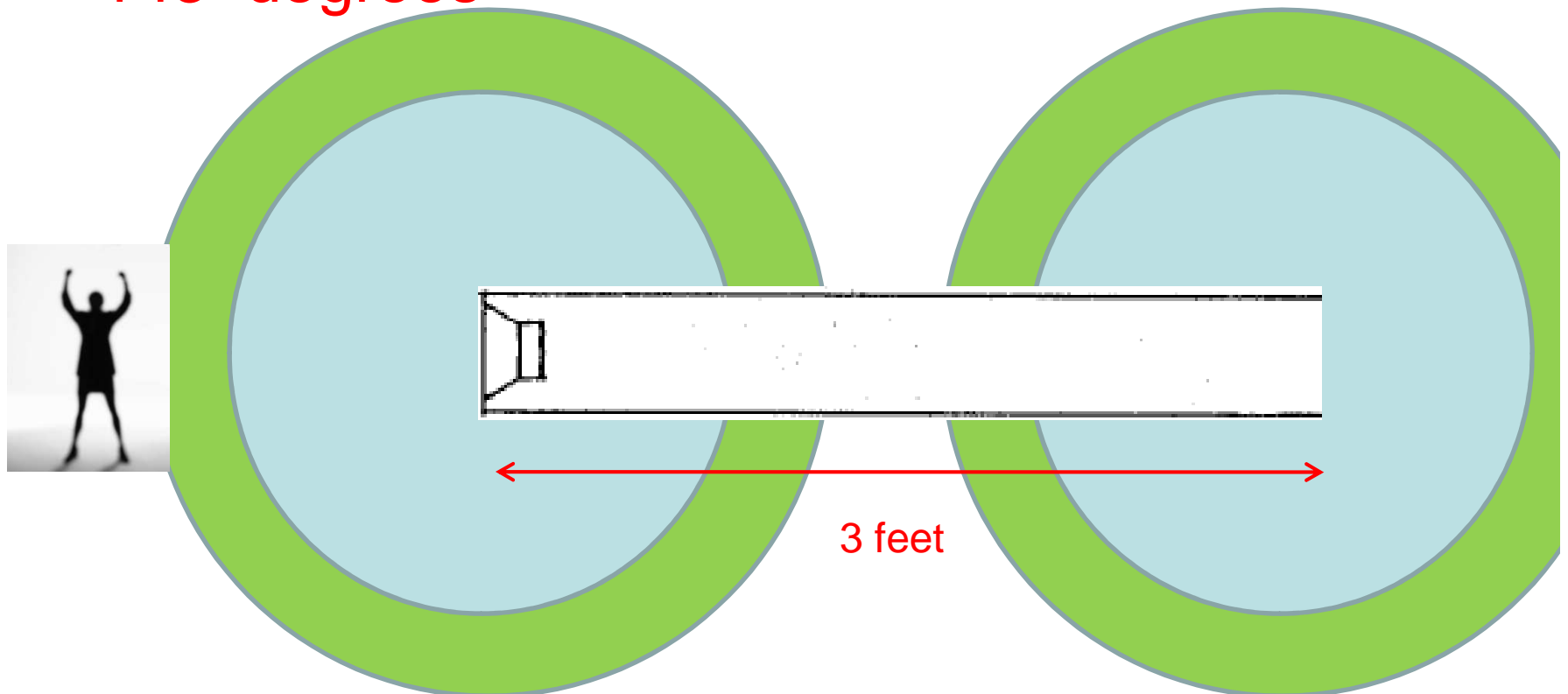

# Application

- what will be level of “combined” signal at observation point?

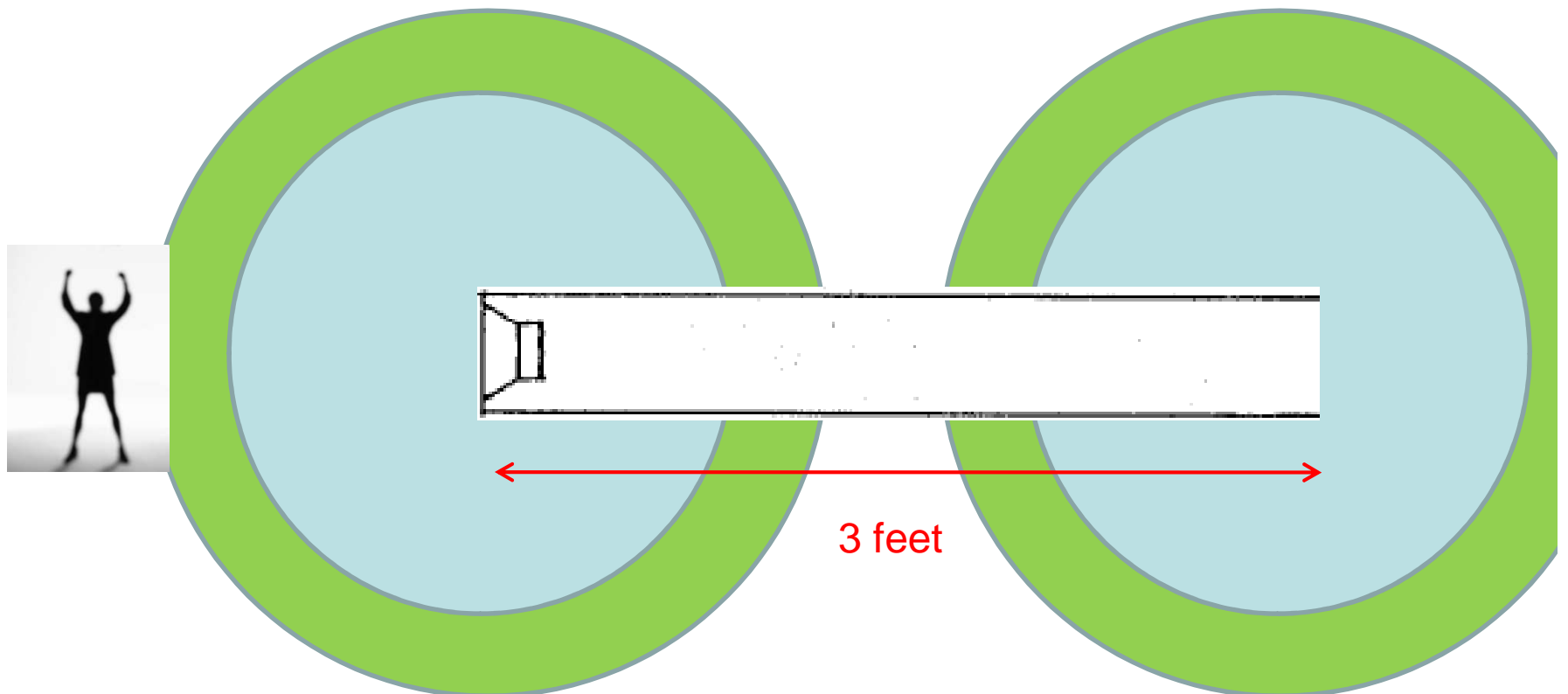

# Application

- what will be level of “combined” signal at observation point? total “round trip” phase shift =  $180+143+143=466$  degrees (106 degrees net); combined level will be 1.7 dB

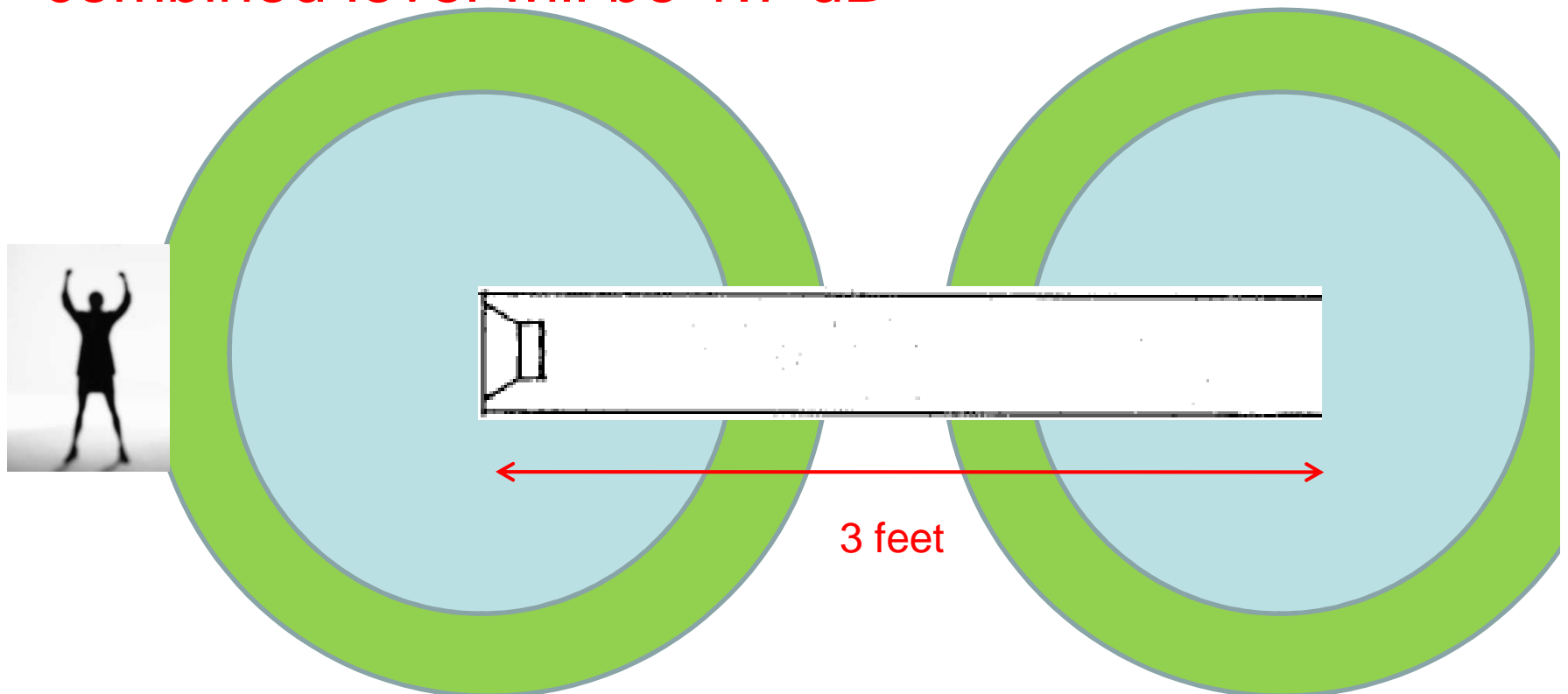

# Application

- if frequency changed to 100 Hz, what will be combined level? **wavelength is 11.3 feet; phase shift traversing pipe 96 degrees; round trip phase shift is 371 degrees (nearly “in phase”); combined level is +5.95 dB**

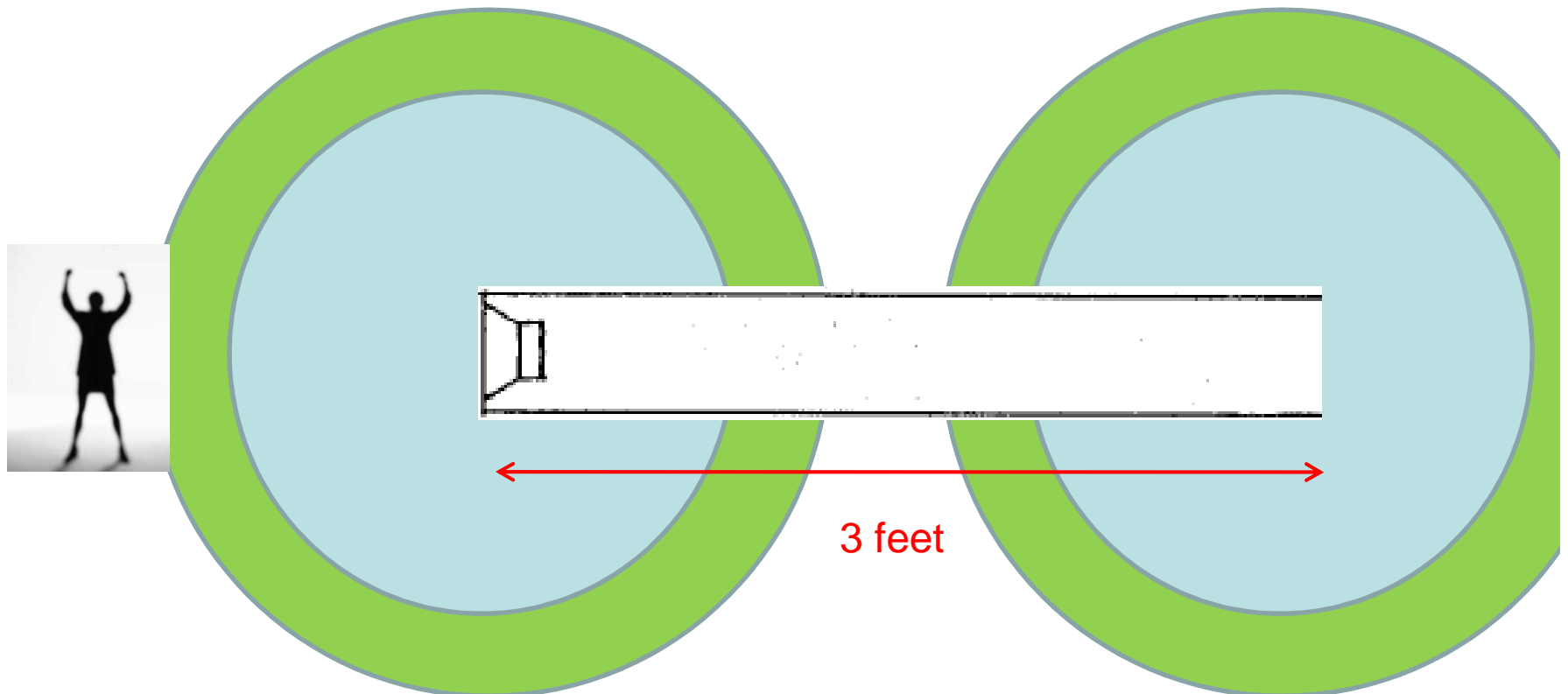

# Coverage / Beamwidth

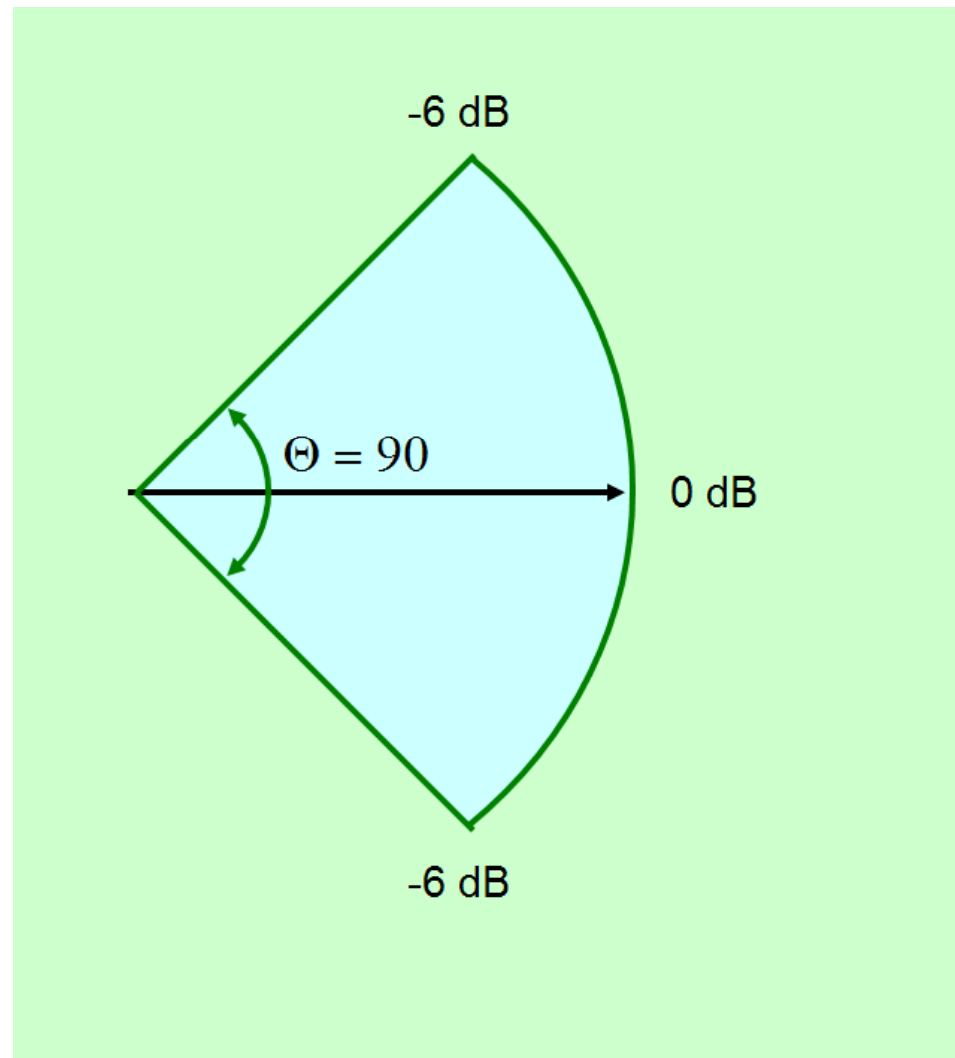

## Common Representations of Loudspeaker Coverage

- Coverage angle  $C_{<}$  (H / V) = 6 dB Beamwidth
- Polar pattern
- Equal level (isobaric) contours (“isobars”)
- Directivity factor (Q)
- Directivity index ( $D_i$ ) =  $10 \log Q$  (also known as “front to back ratio”)
- Beamwidth vs. frequency
- 3D “balloons”

## Speaker Directivity: Coverage Pattern Renderings

Comparing protractor, equal level contour and polar plots for two different "90 degree" speakers

Radial horn pattern as equal level contours

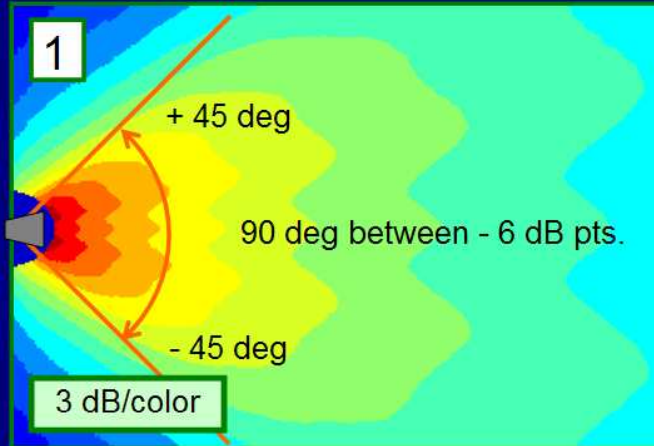

Front loaded cone driver pattern as equal level contours

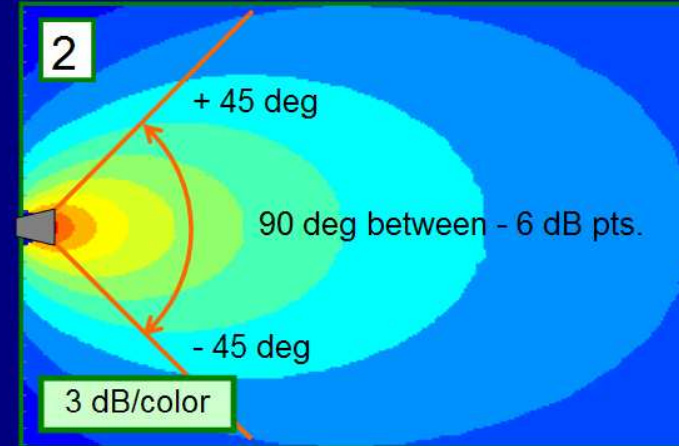

Front loaded cone driver pattern as a polar plot

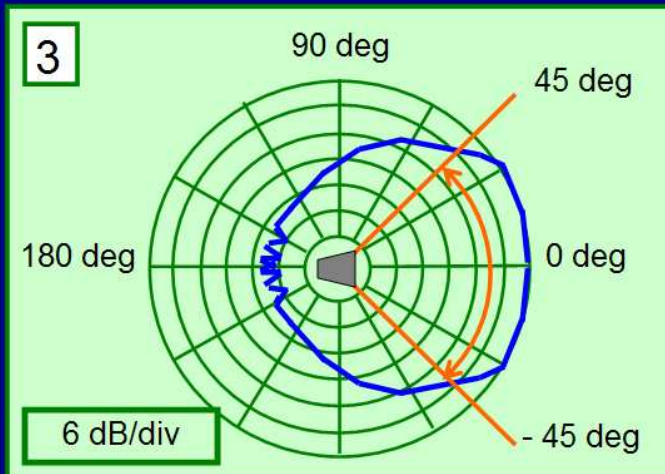

Front loaded cone driver pattern as a polar plot

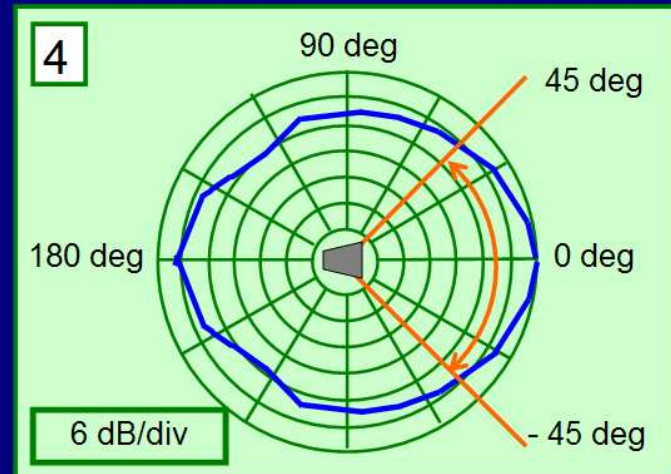

Example: Piston radiation into half-space (e.g., a cone-type loudspeaker mounted in an “infinite” baffle)

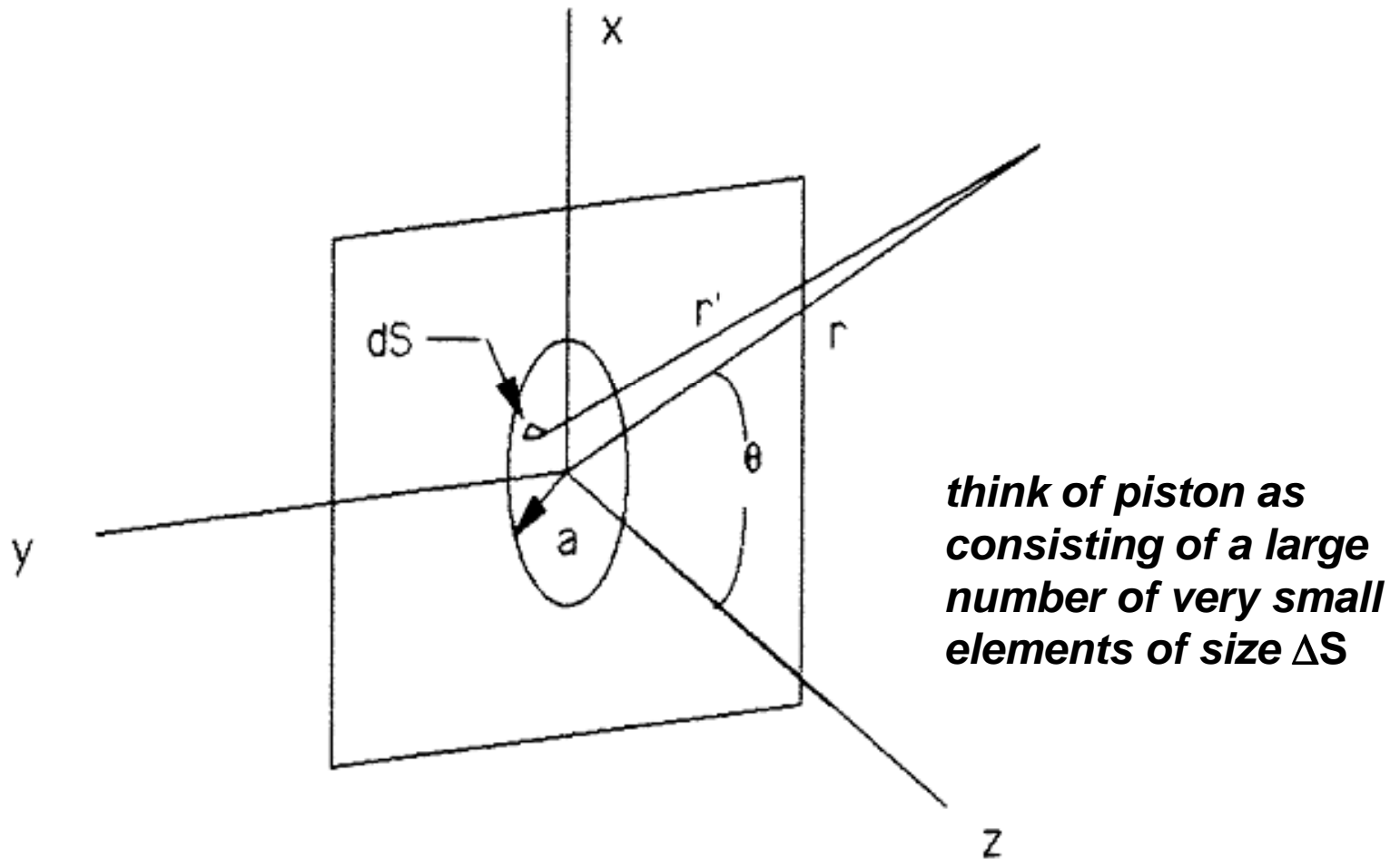

- integrating over the entire piston surface yields

$$p(r,t,\theta) = -\frac{\rho_0 \omega u_m S}{2\pi r} \sin(\omega t - kr) \left[ \frac{2J_1(ka \sin\theta)}{ka \sin\theta} \right]$$

where  $S$  is the piston area  $\pi a^2$  and  $J_1$  is a **Bessel function of first order**

$$p(r,t,\theta) = -\frac{\rho_0 \omega u_m a^2}{2r} \sin(\omega t - kr) \left[ \frac{2J_1(ka \sin\theta)}{ka \sin\theta} \right]$$

- plot of  $2 J_1(x)/x$

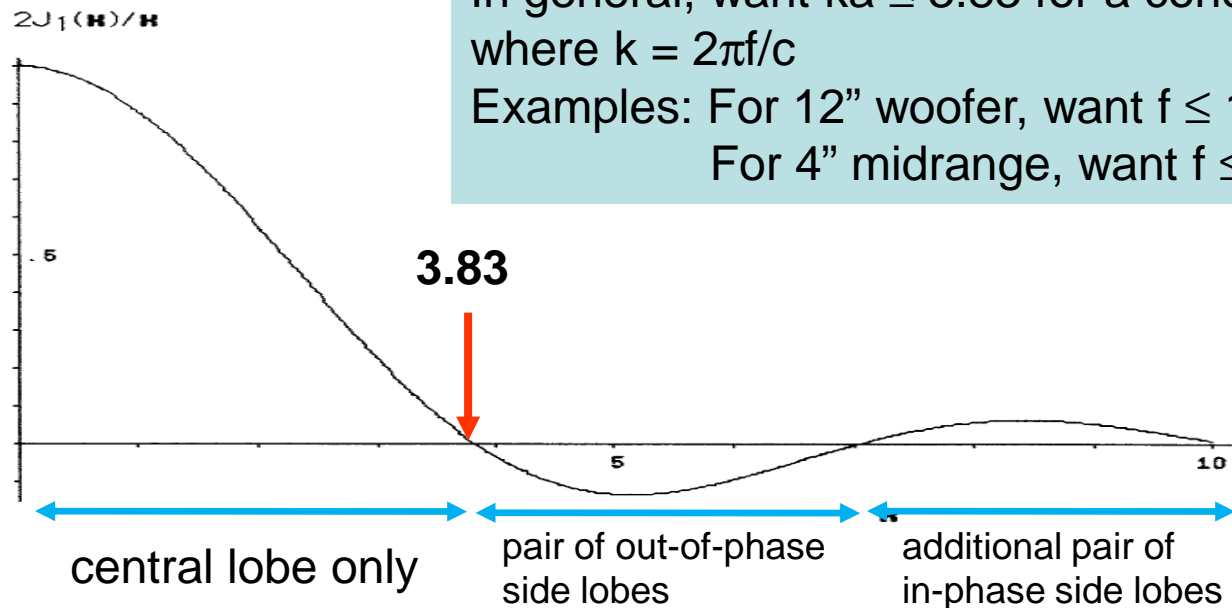

- directivity pattern of a flat piston for three different frequencies

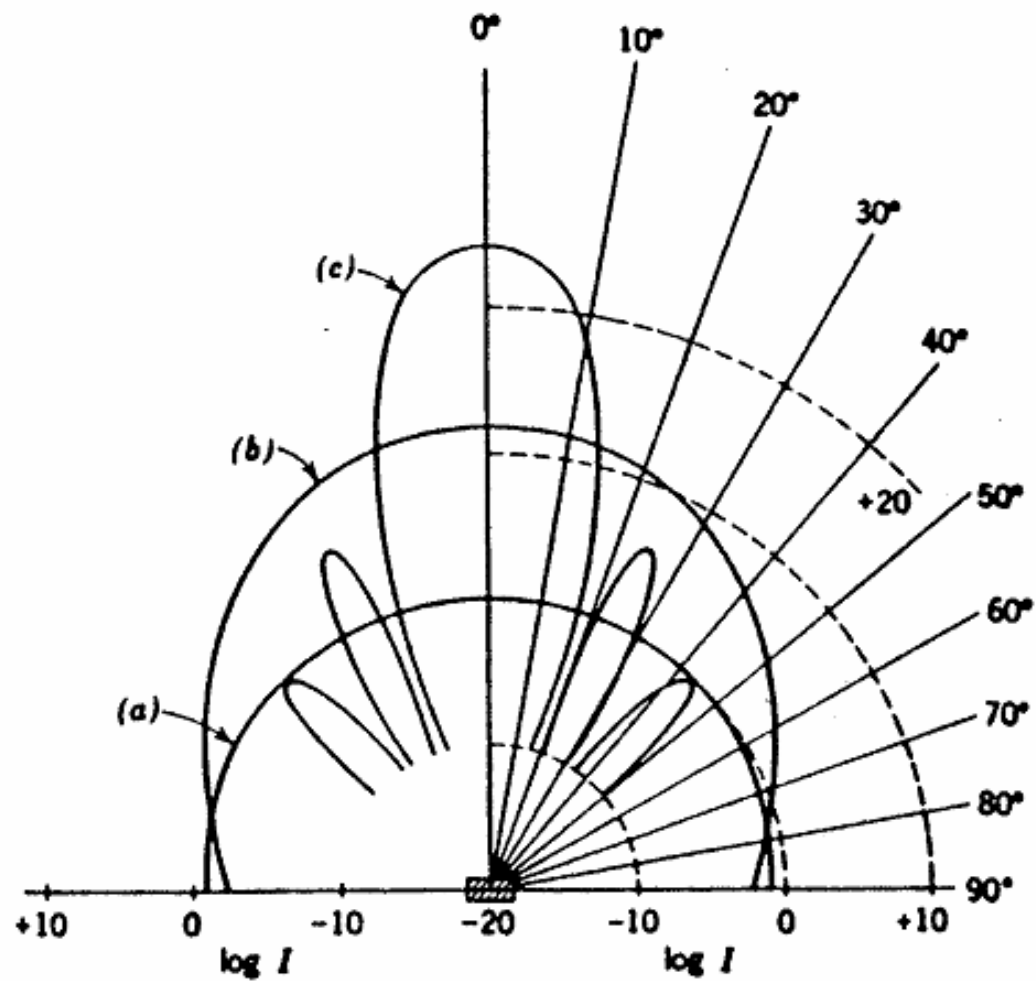

(a)  $\lambda=8a$ , (b)  $\lambda=2a$ , (c)  $\lambda=a/2$

# Single 4-inch Loudspeaker

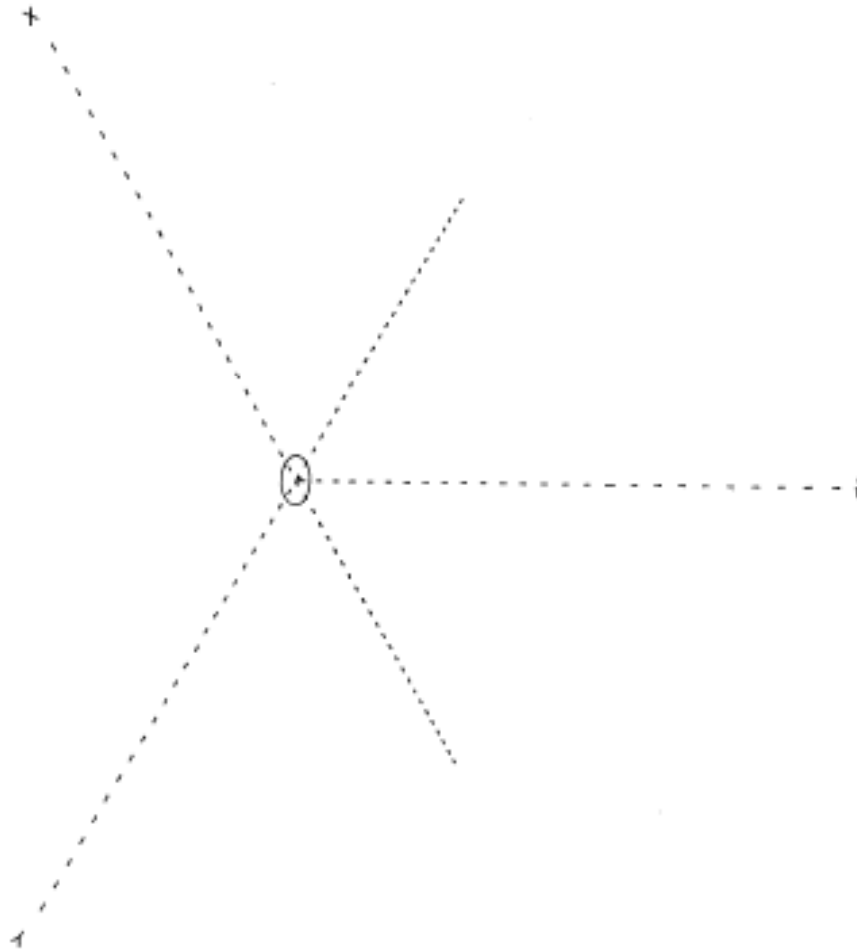

# Single 4-inch Loudspeaker @ 500 Hz

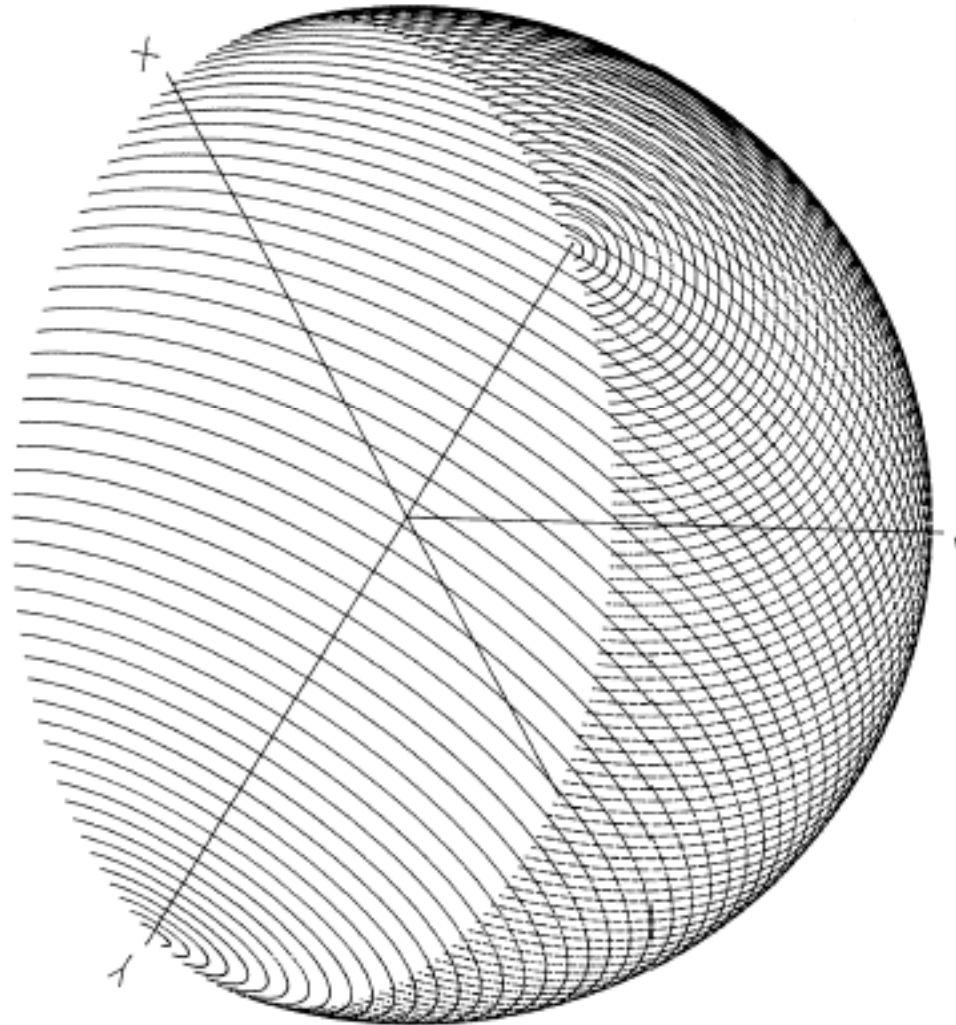

# Single 4-inch Loudspeaker @ 1000 Hz

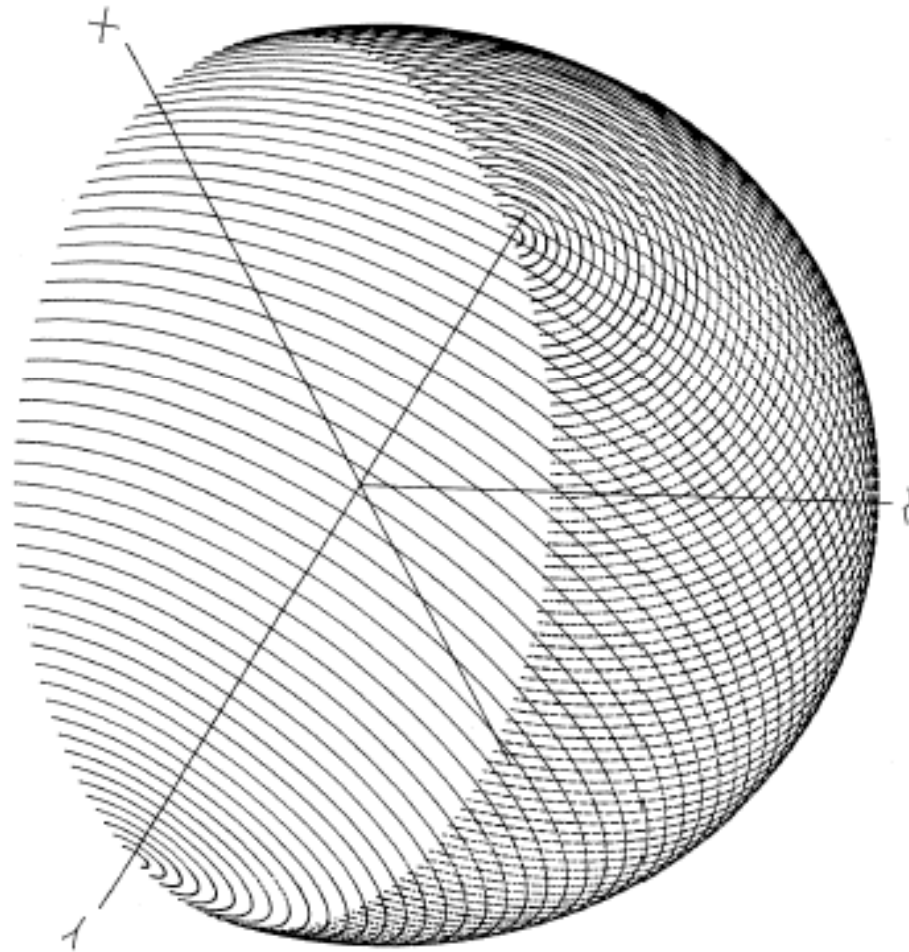

# Single 4-inch Loudspeaker @ 2000 Hz

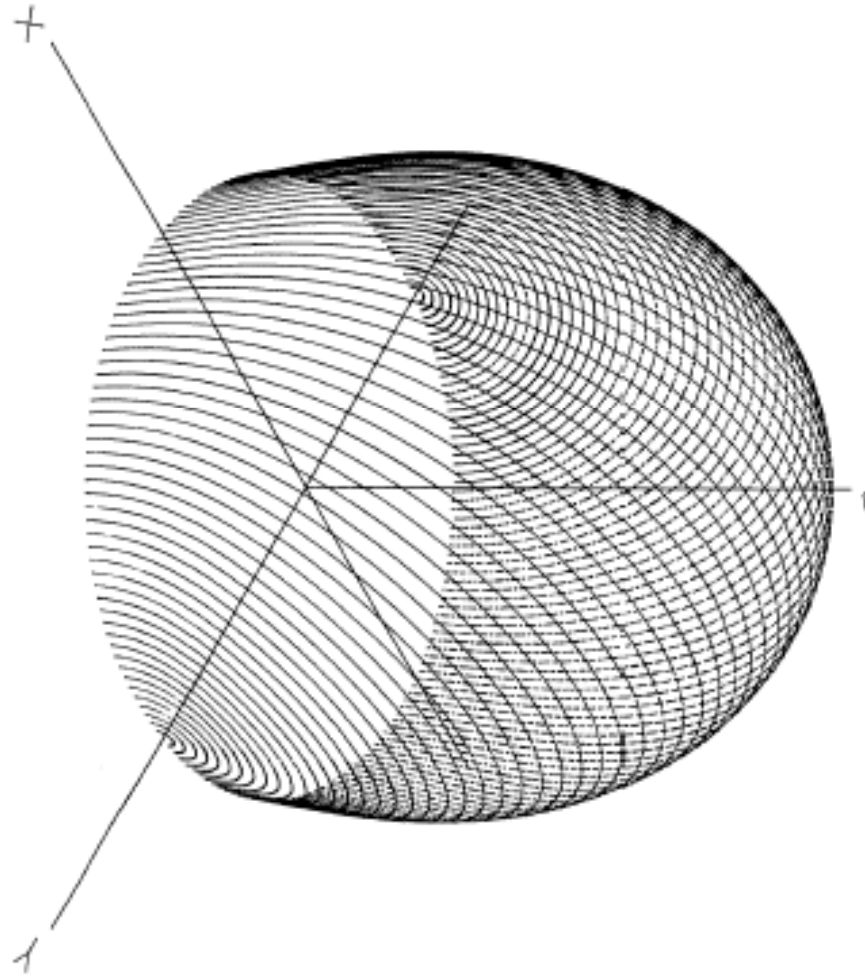

# Single 4-inch Loudspeaker @ 4000 Hz

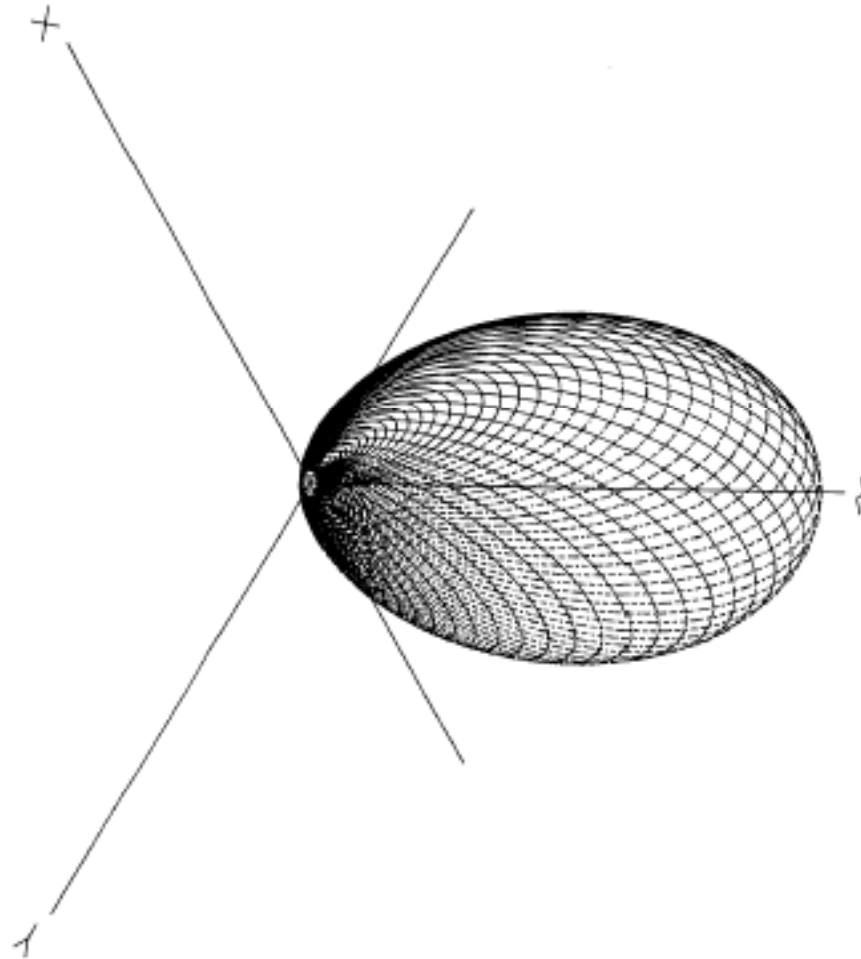

# 32-Element Array of 4-inch Drivers

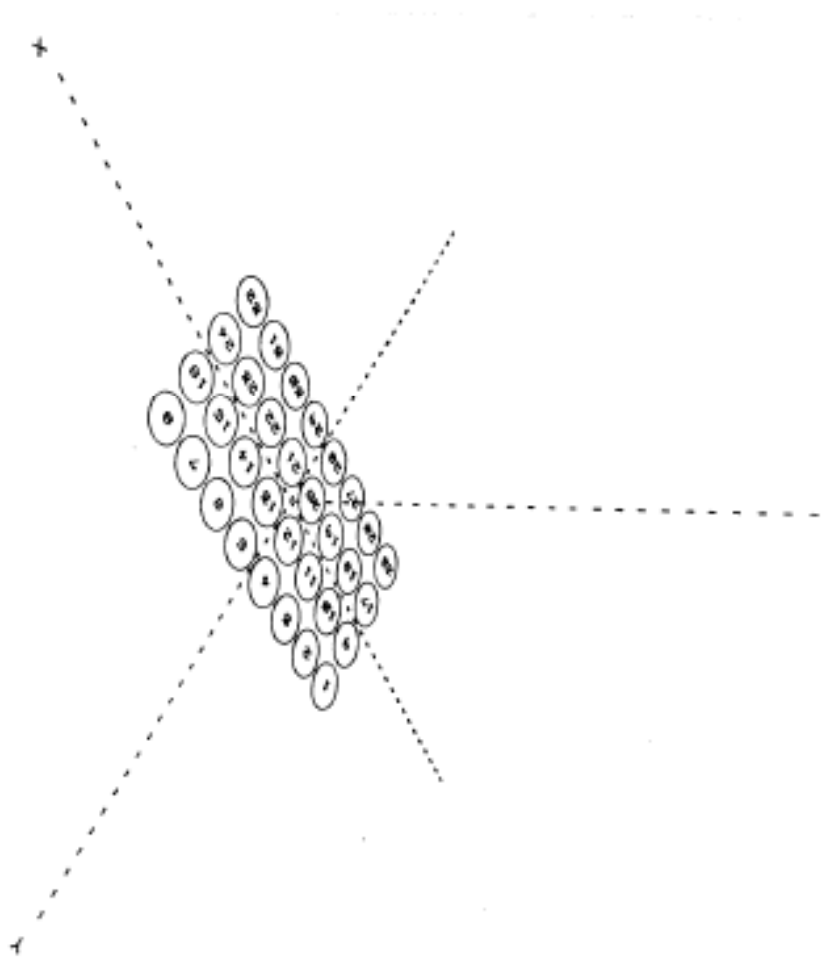

# 32-Element Array @ 500 Hz

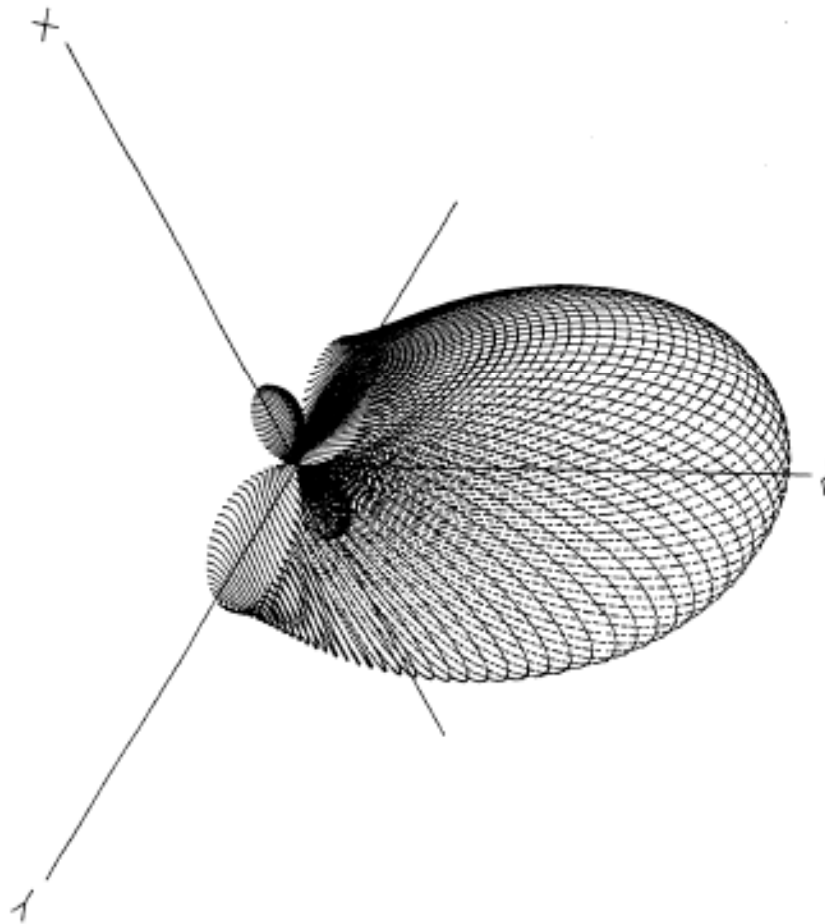

# 32-Element Array @ 1000 Hz

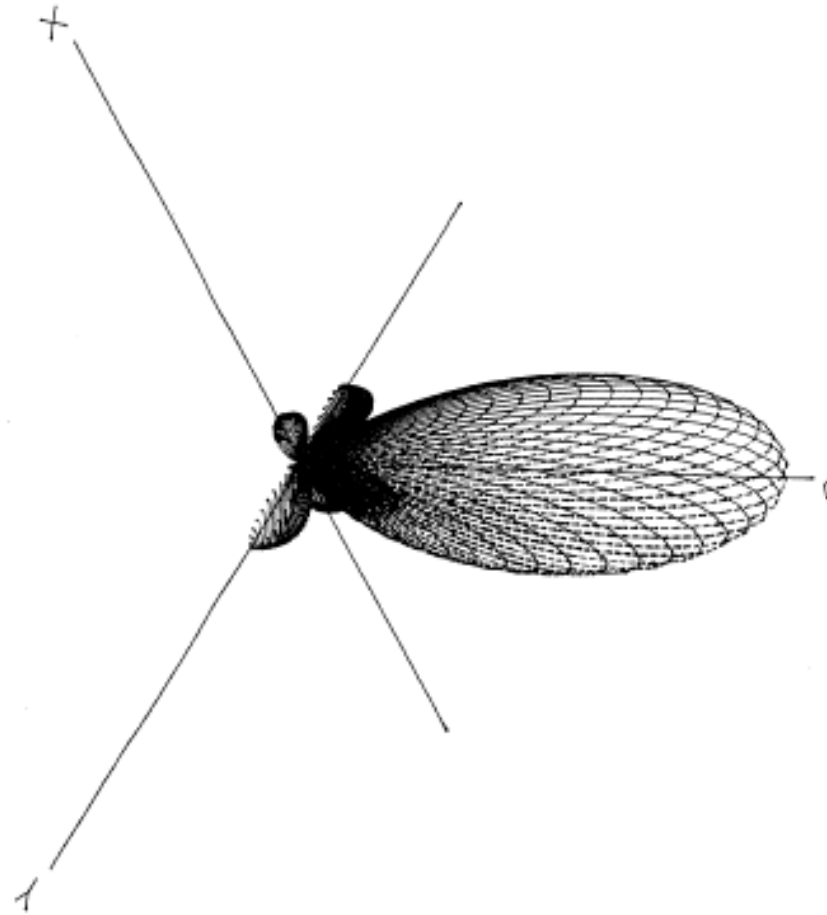

# 32-Element Array @ 2000 Hz

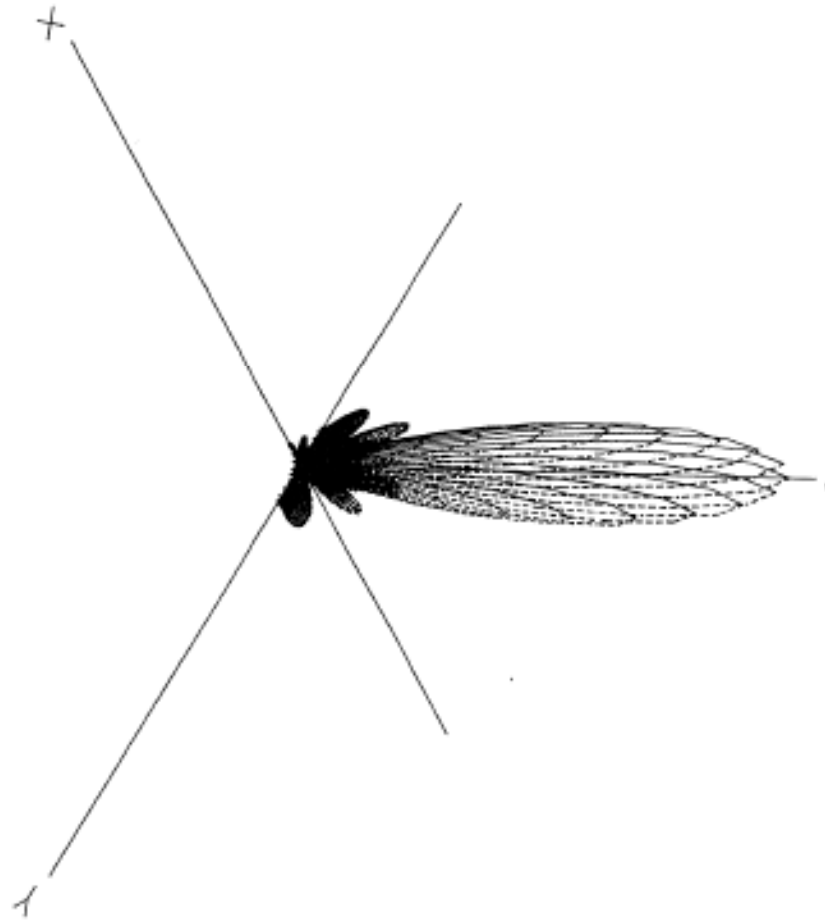

# 32-Element Array @ 4000 Hz

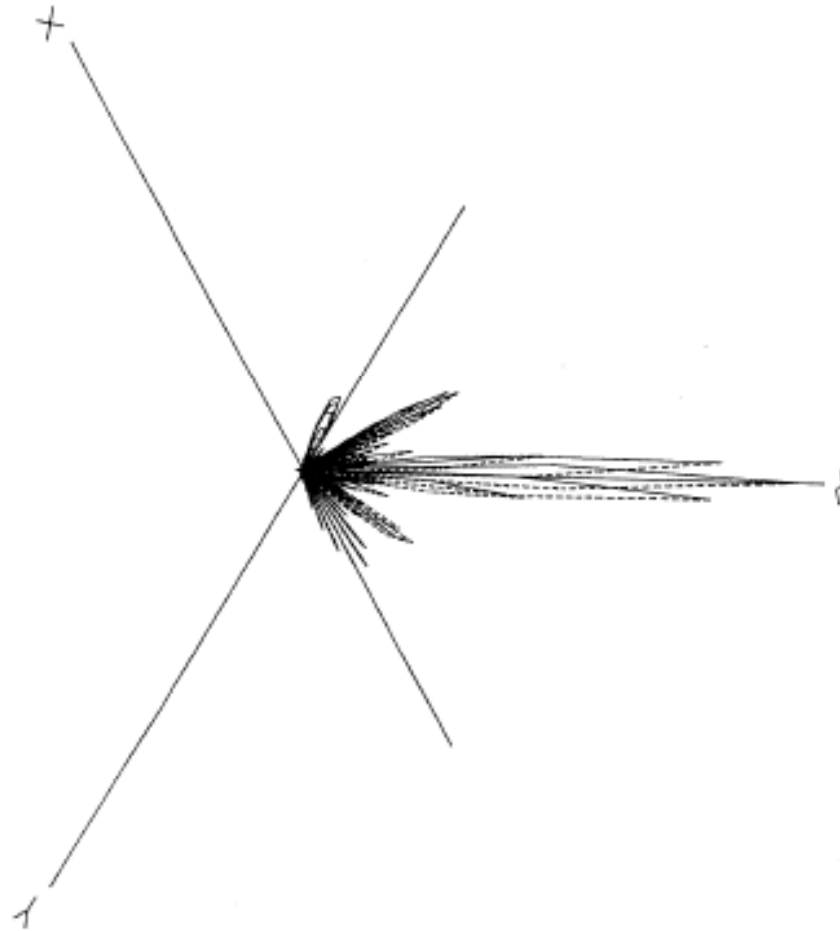

# “Home Stereo” Multi-way System

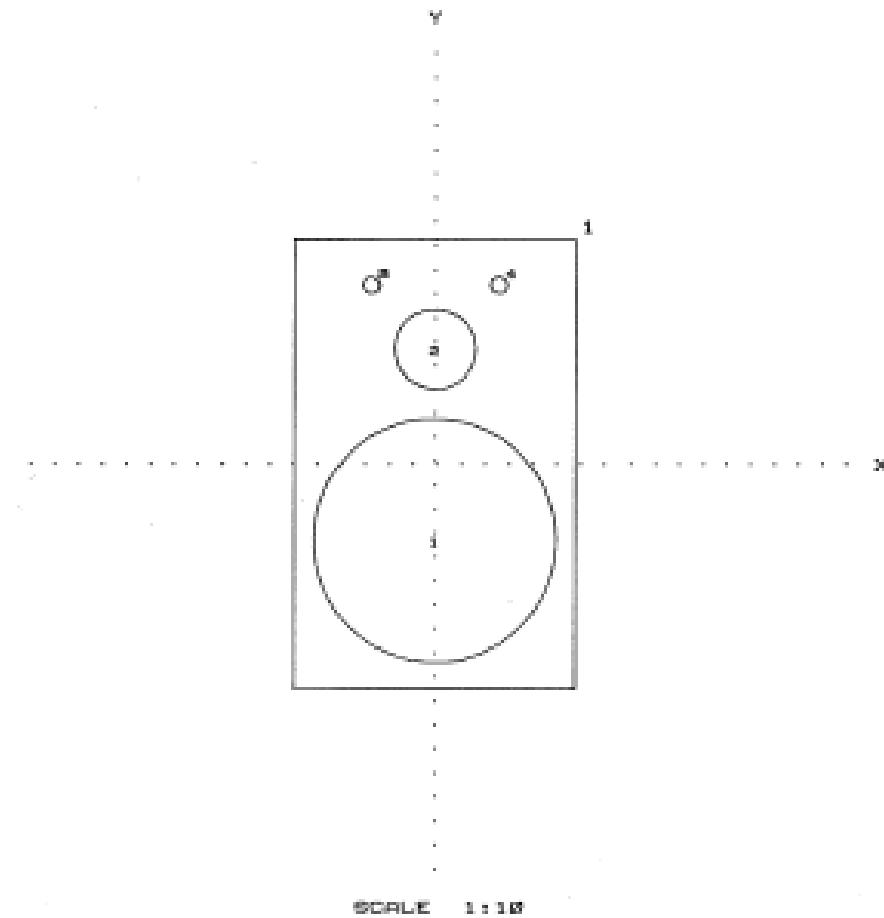

# “Home Stereo” Multi-way System

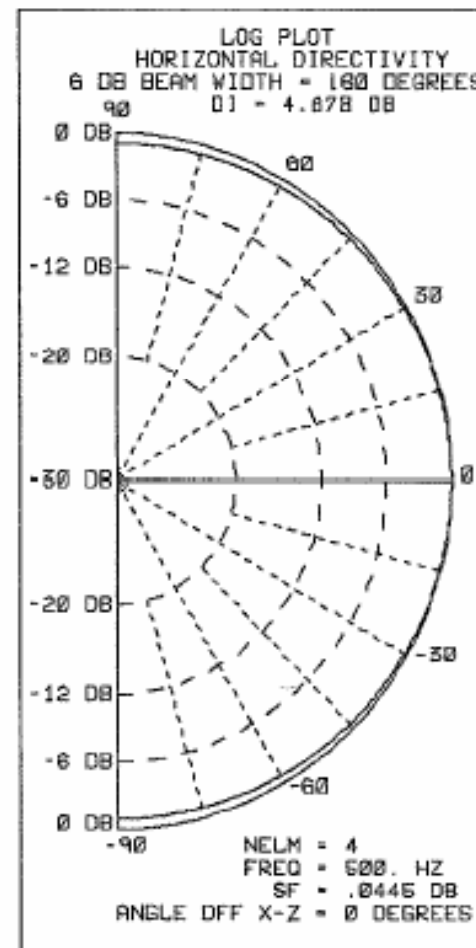
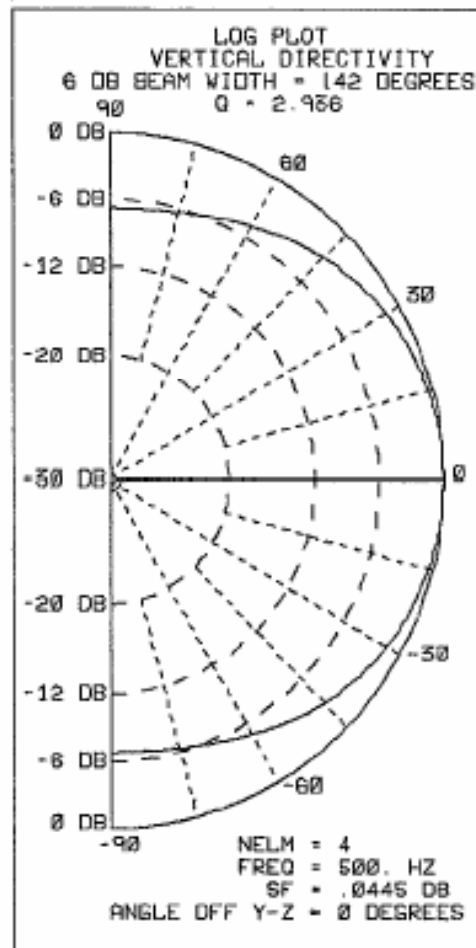

# “Home Stereo” Multi-way System

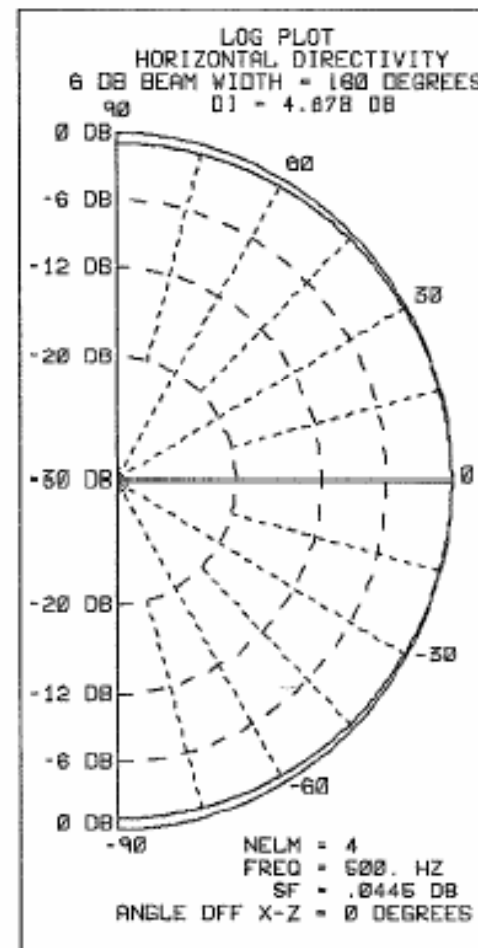
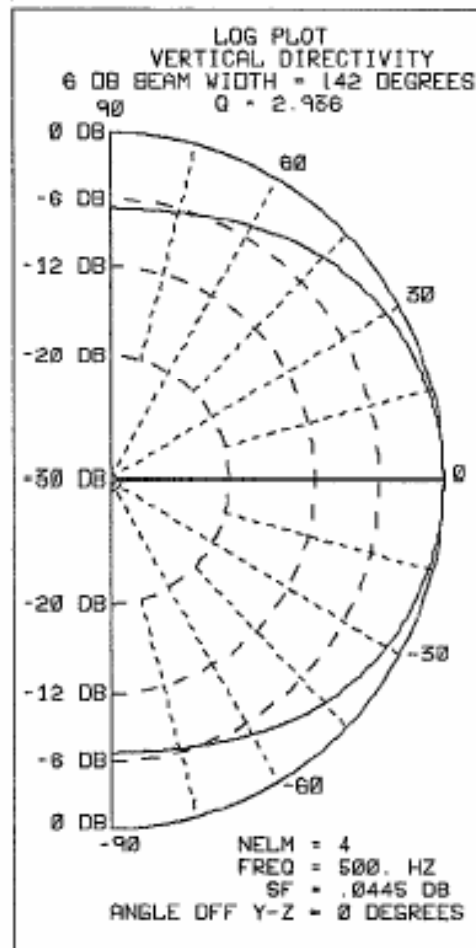

# “Home Stereo” Multi-way System

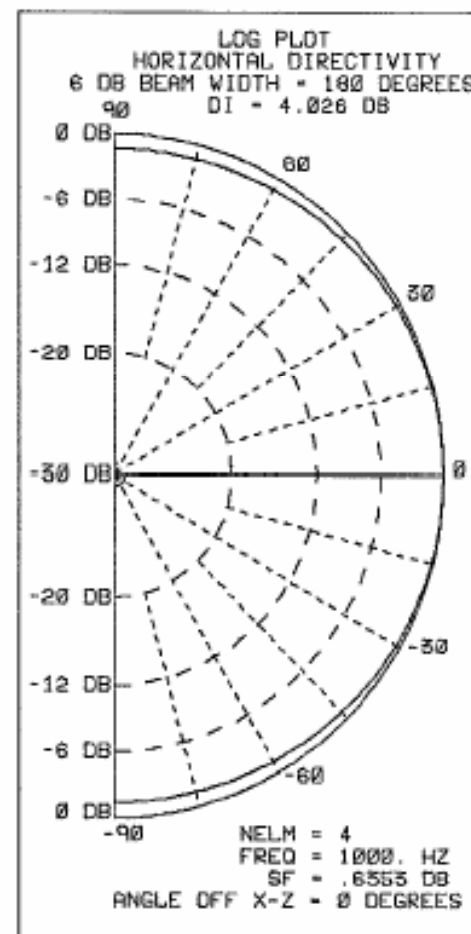
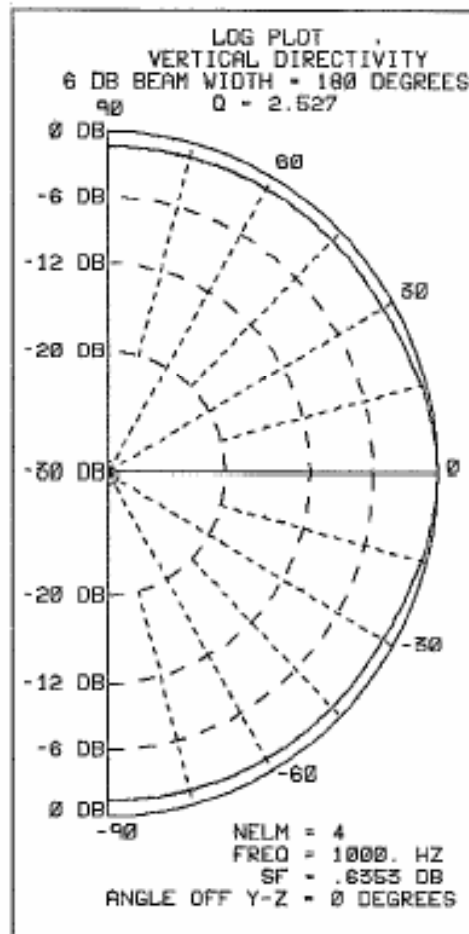

# “Home Stereo” Multi-way System

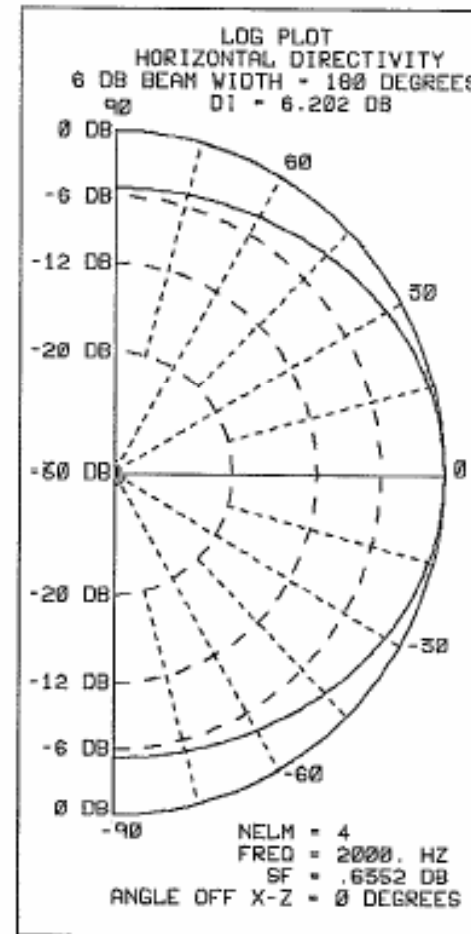
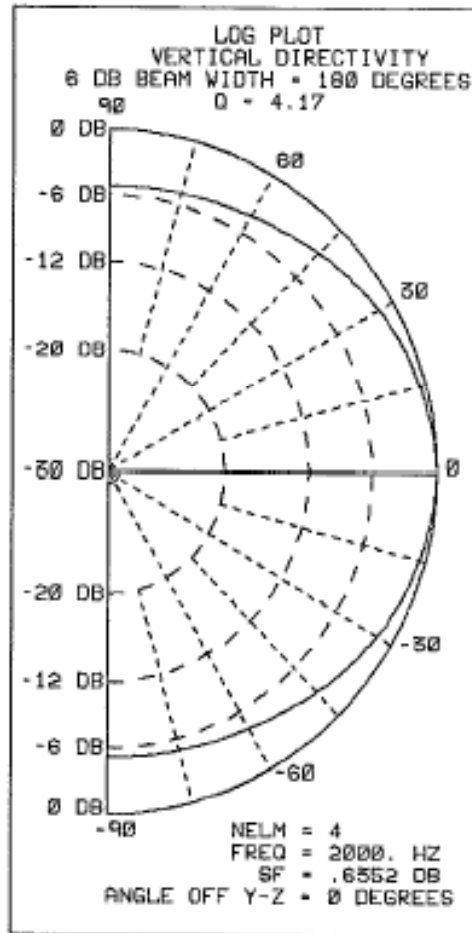

# “Home Stereo” Multi-way System

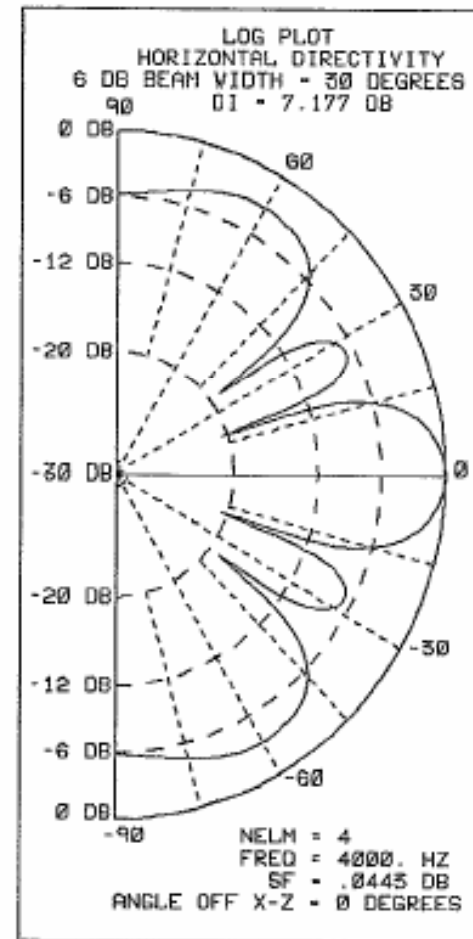
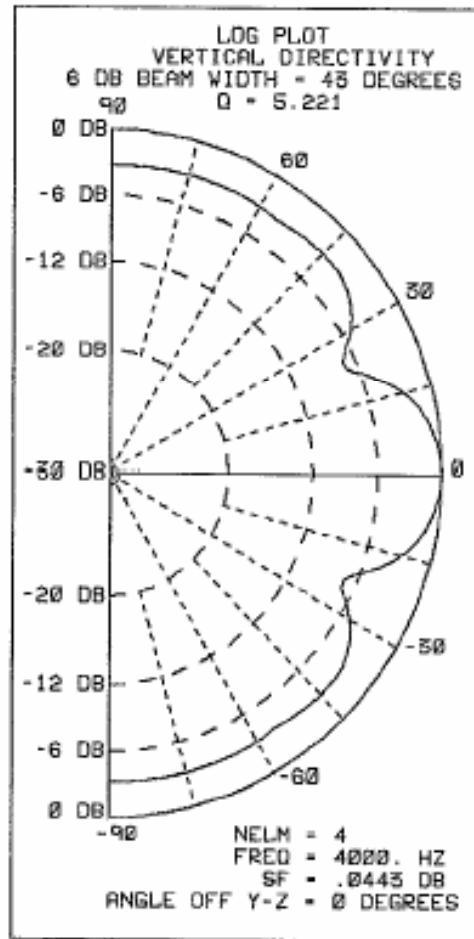

# “Home Stereo” Multi-way System

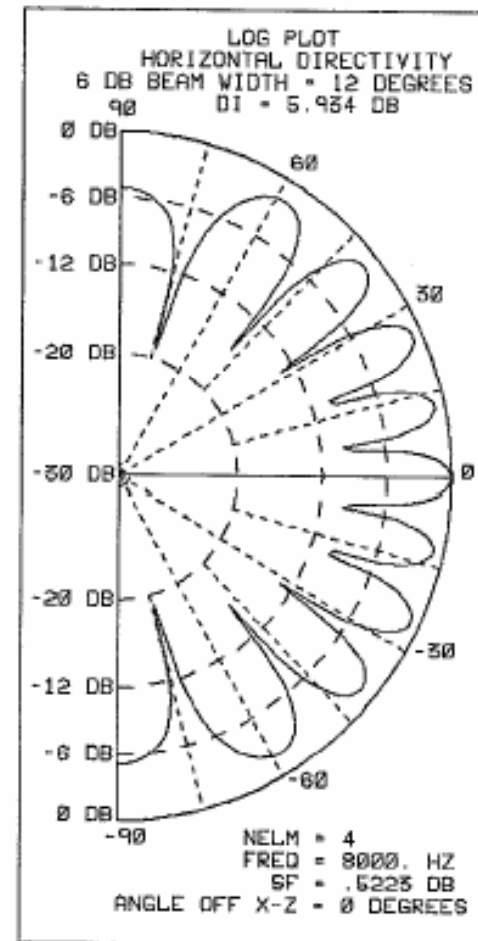
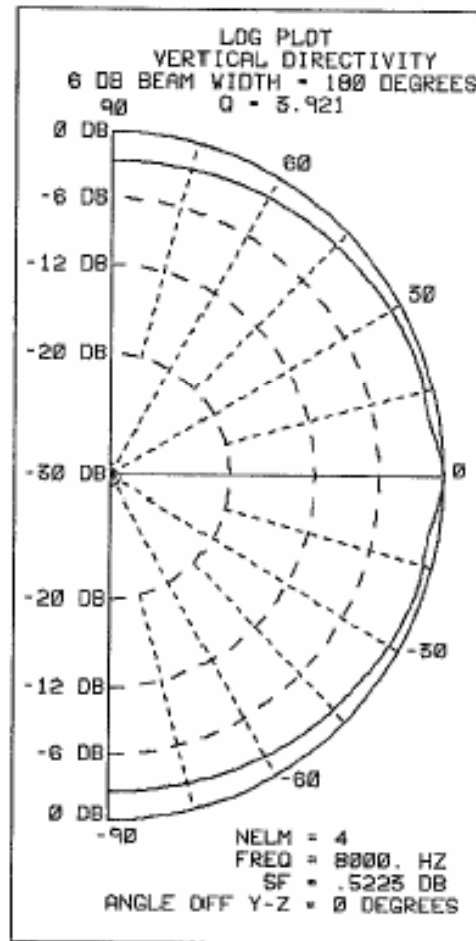

# Outline

- **Overview of enclosure types**
  - **Infinite baffle**
  - **Sealed box**
  - **Bass reflex (vented/ported)**
  - **Passive radiator**
  - **Horn (front and rear loaded)**
  - **Transmission line (labyrinth)**
  - **Tapered tube (damped pipe/“waveguide”)**

# Infinite Baffle

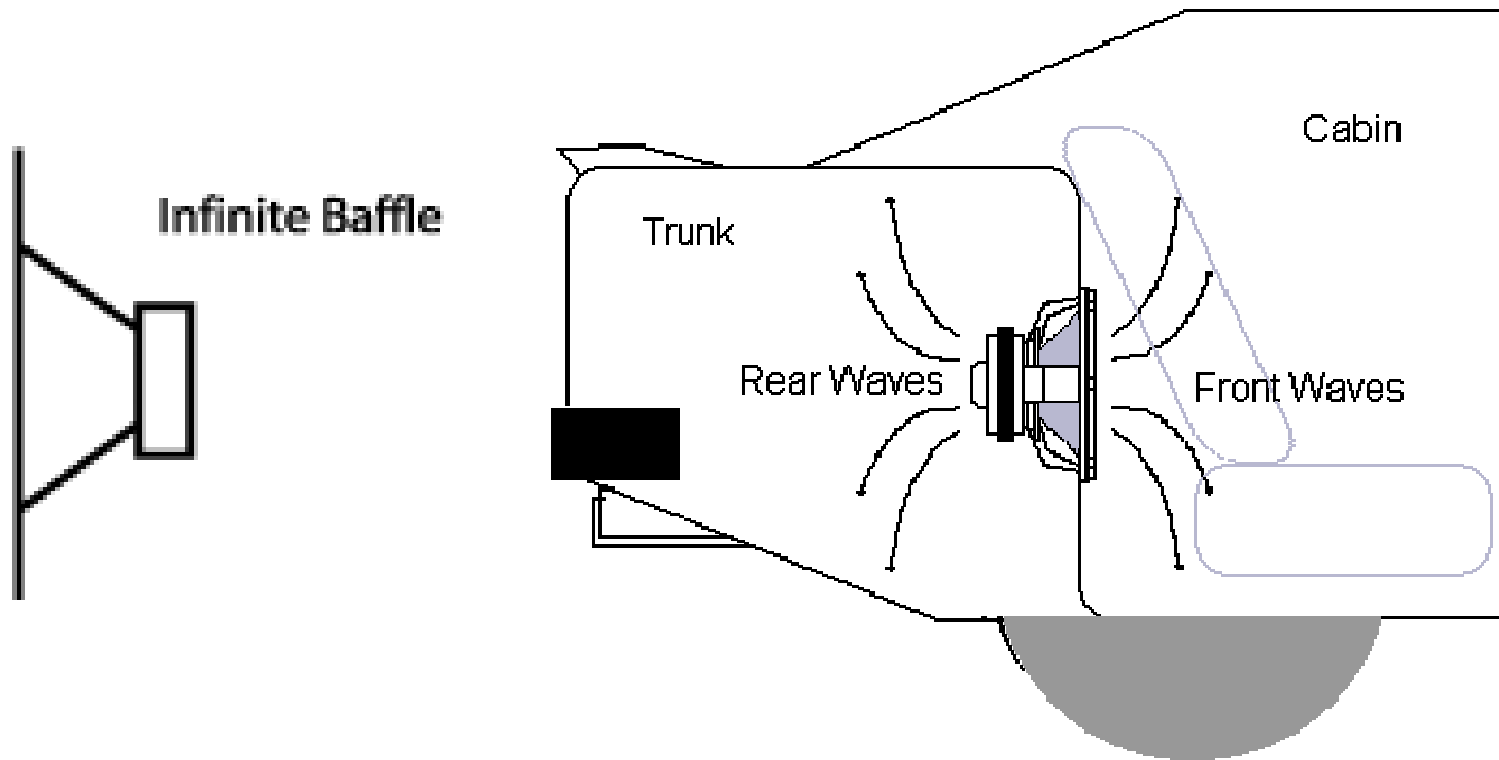

# Sealed Box

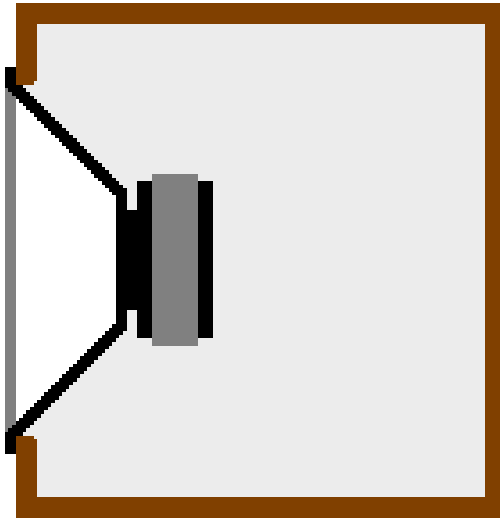

# Bass Reflex

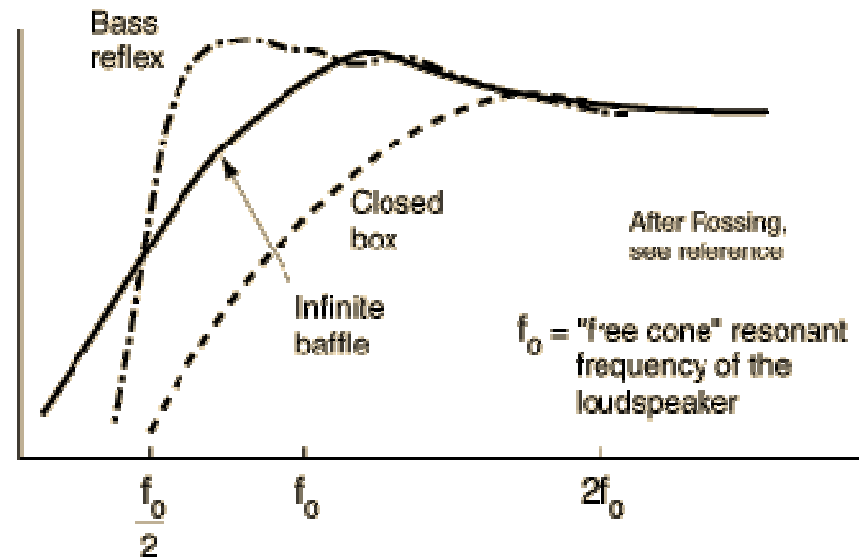
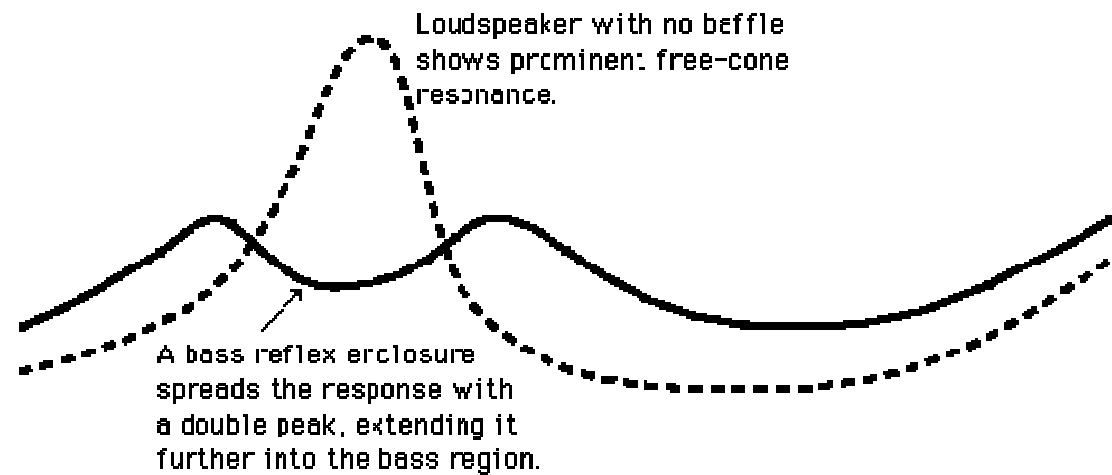
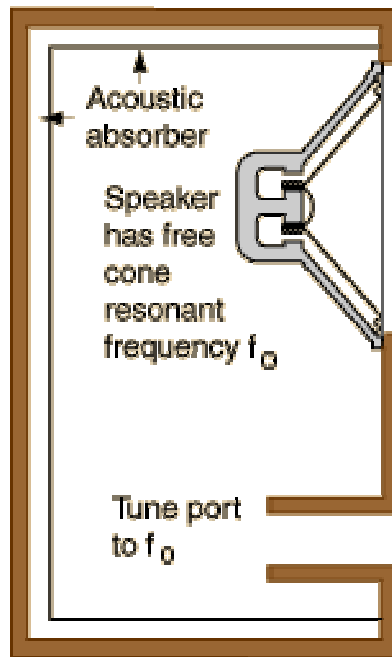

# Measurement of Loudspeaker Free-Air Resonance

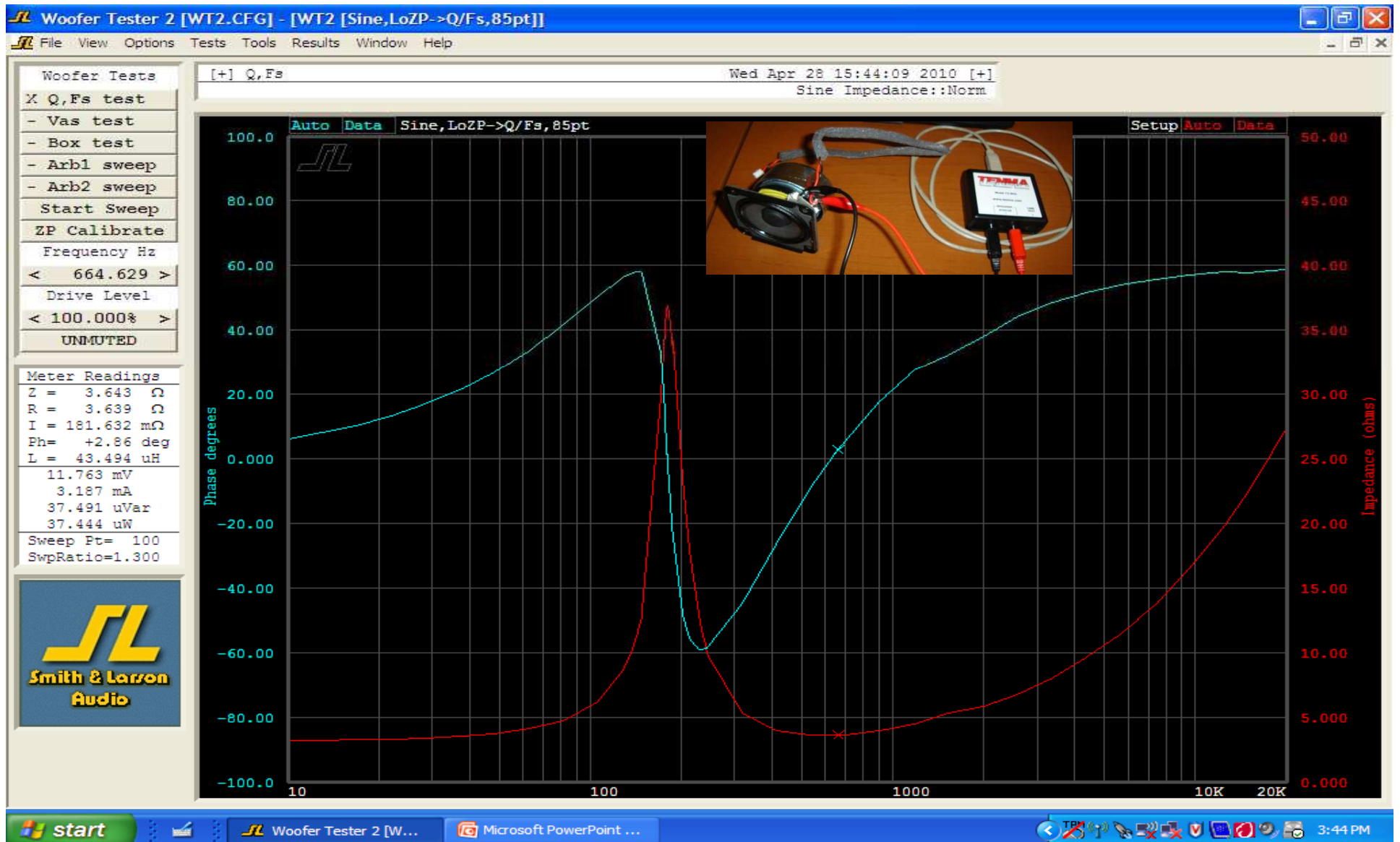

# Passive Radiator

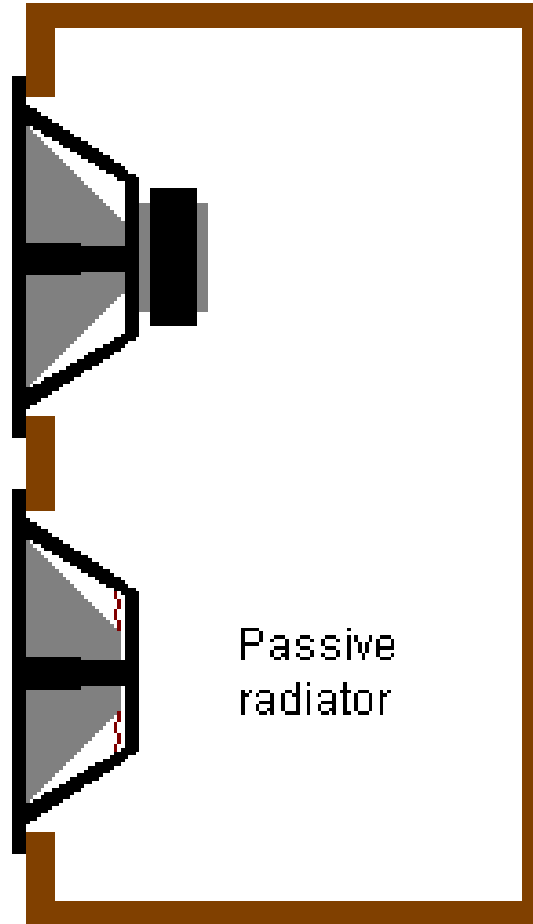

Comment: primarily applicable to subwoofer design

# Compound / Band-pass

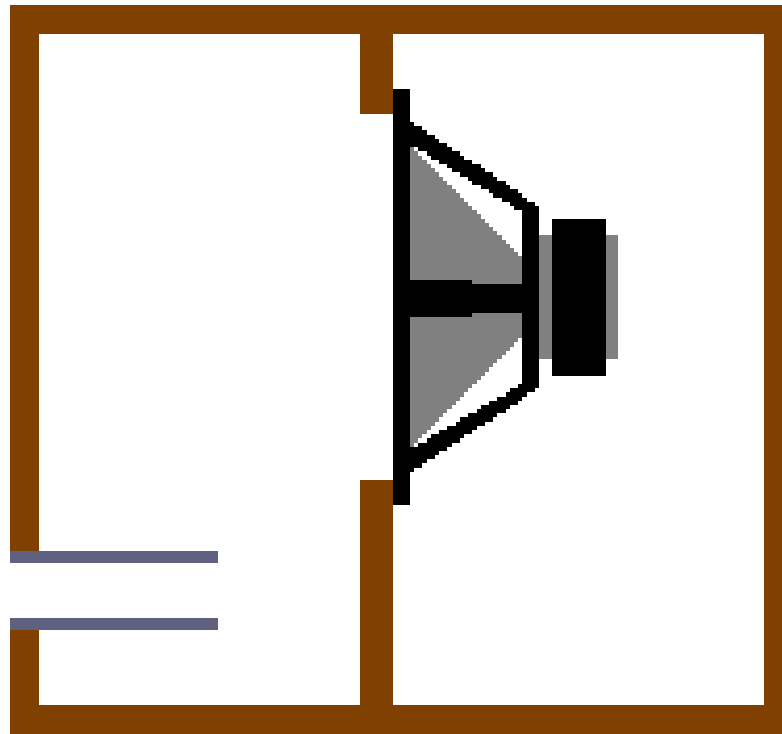

Comment: primarily applicable to subwoofer design

# Front-loaded Horn

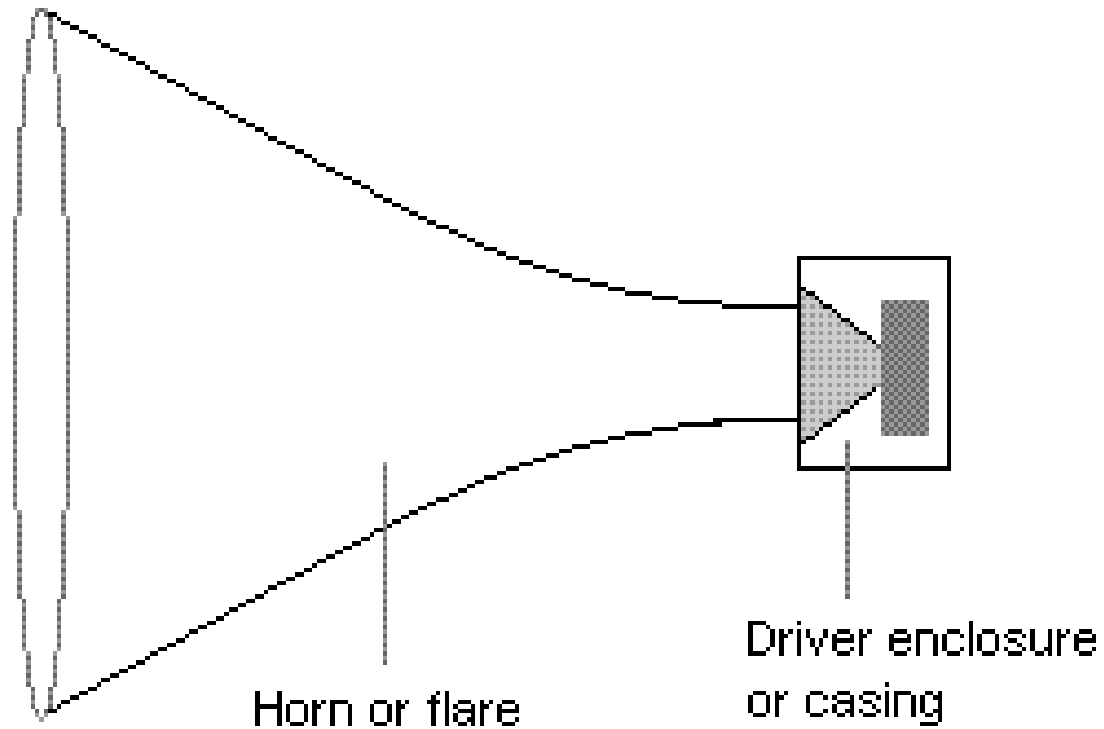

Comment: primarily applicable to mid/high frequencies

# Rear-loaded Horn

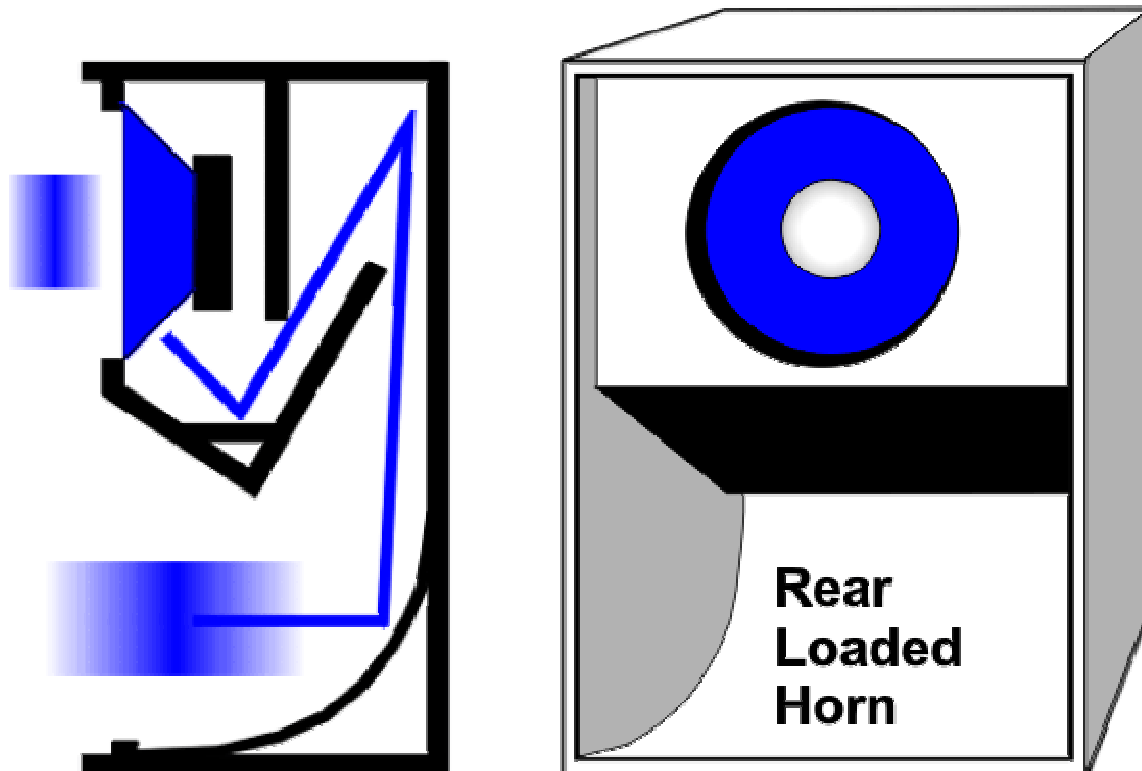

Comment: physically large!

# Transmission Line / Labyrinth

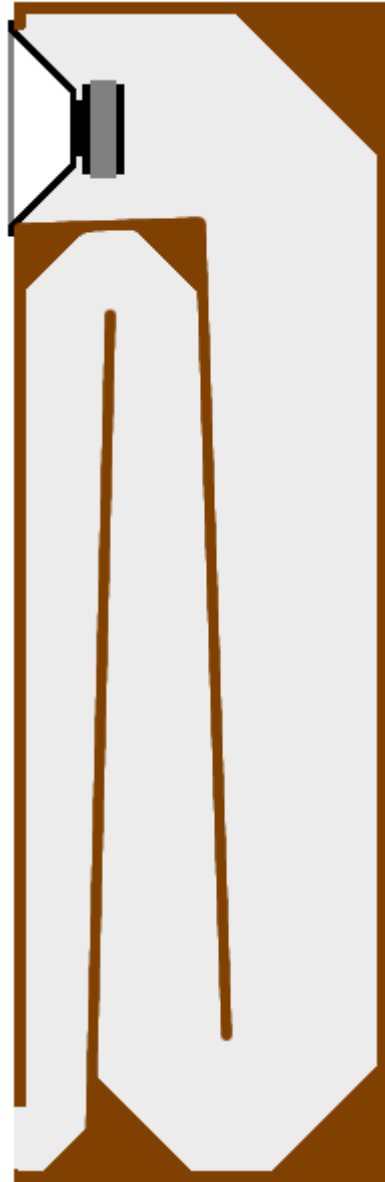

Length of transmission line has to be long enough to provide at least  $90^\circ$  of phase shift ( $1/4$  of longest wavelength of interest)

Phase shift (degrees) =  
 $360 \times L / (C/F)$   
where  $L$  is effective length of labyrinth,  $C$  is speed of sound, and  $F$  is frequency of operation (note – add 180 due to rear radiation)

# Transmission Line / Labyrinth

- Transmission line – typically “heavily damped” (stuffed with acoustic material) to absorb energy from rear vibrating surface (or limit radiation from vent to low frequencies)
- Labyrinth – typically “lined” (with acoustic absorption material) but otherwise “substantially open” (radiation from vent limited to low frequencies)

# Damped Pipe

- Pipe driven at one end and open at the other will resonate at a frequency of  $F_{res} = C / 4L$ , where  $C$  is the speed of sound (1130 ft/sec at 72° F) and  $L$  is the **effective length** of the pipe ( $F_{res}$  is called its “quarter-wavelength tuning” frequency)
- The **effective (or “acoustic”) length** of the pipe may be longer than its **physical length**
- Use of tapering and/or acoustic absorption material can increase the **effective length**

# Damped Pipe / Tapered Tube

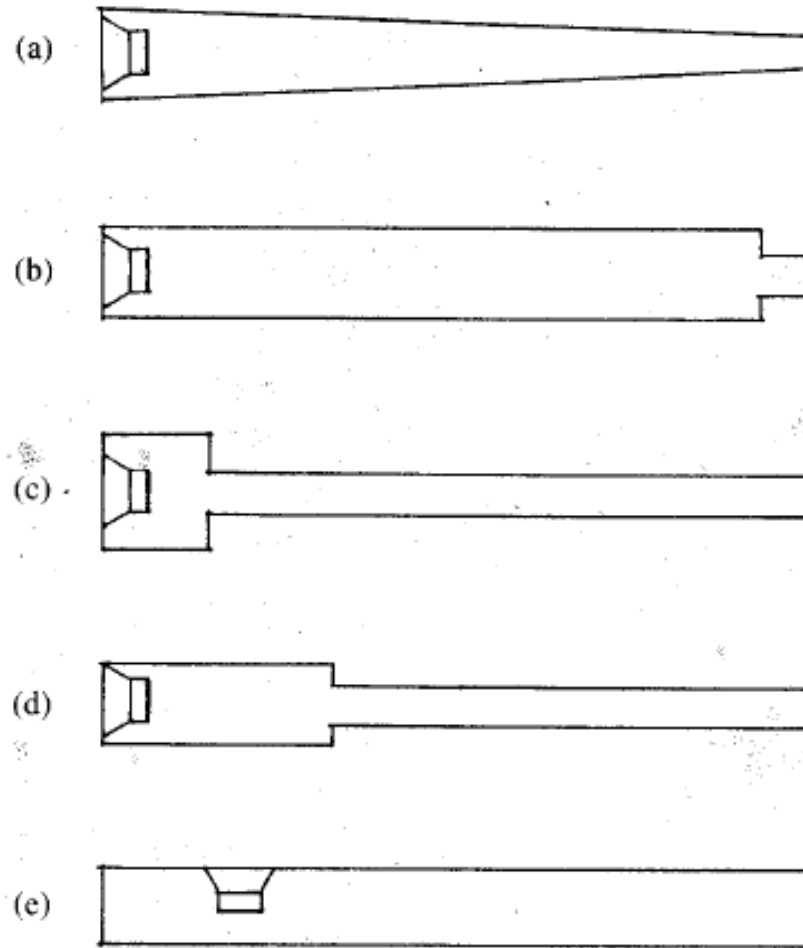

Fig. 9. Alternate pipe geometries. (a) Tapered. (b) Vented. (c) Chamber. (d) Stepped. (e) Offset loudspeaker.

Illustration from: G. L. Augspurger, "Loudspeakers on Damped Pipes," *J. Audio Eng. Soc.*, vol. 48, pp. 424-436 (2000 May).

# Bose AWR1 "Waveguide"

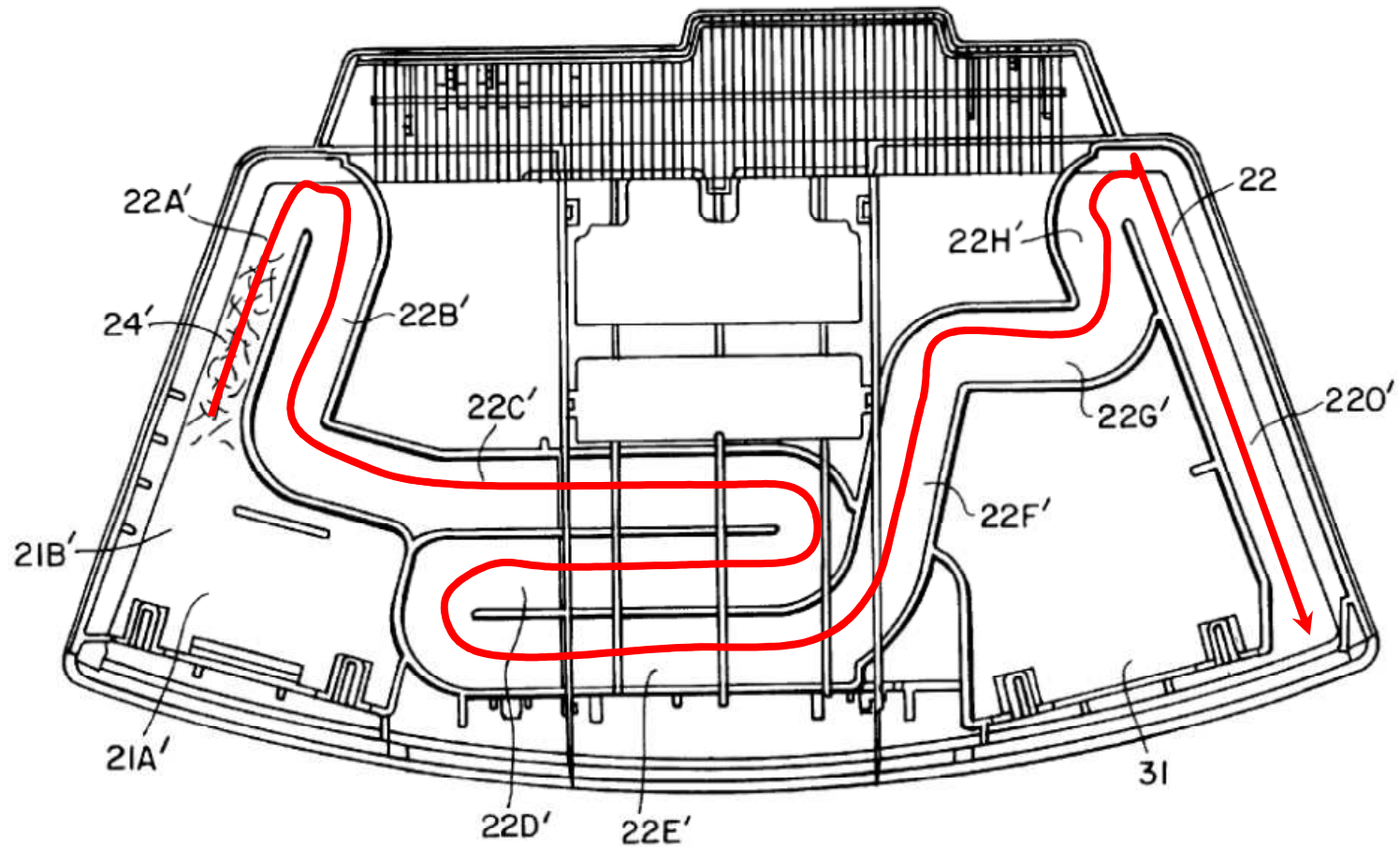

Illustration from: Fig. 4 of U.S. Patent 6,278,789

# Bose WRII "Waveguide"

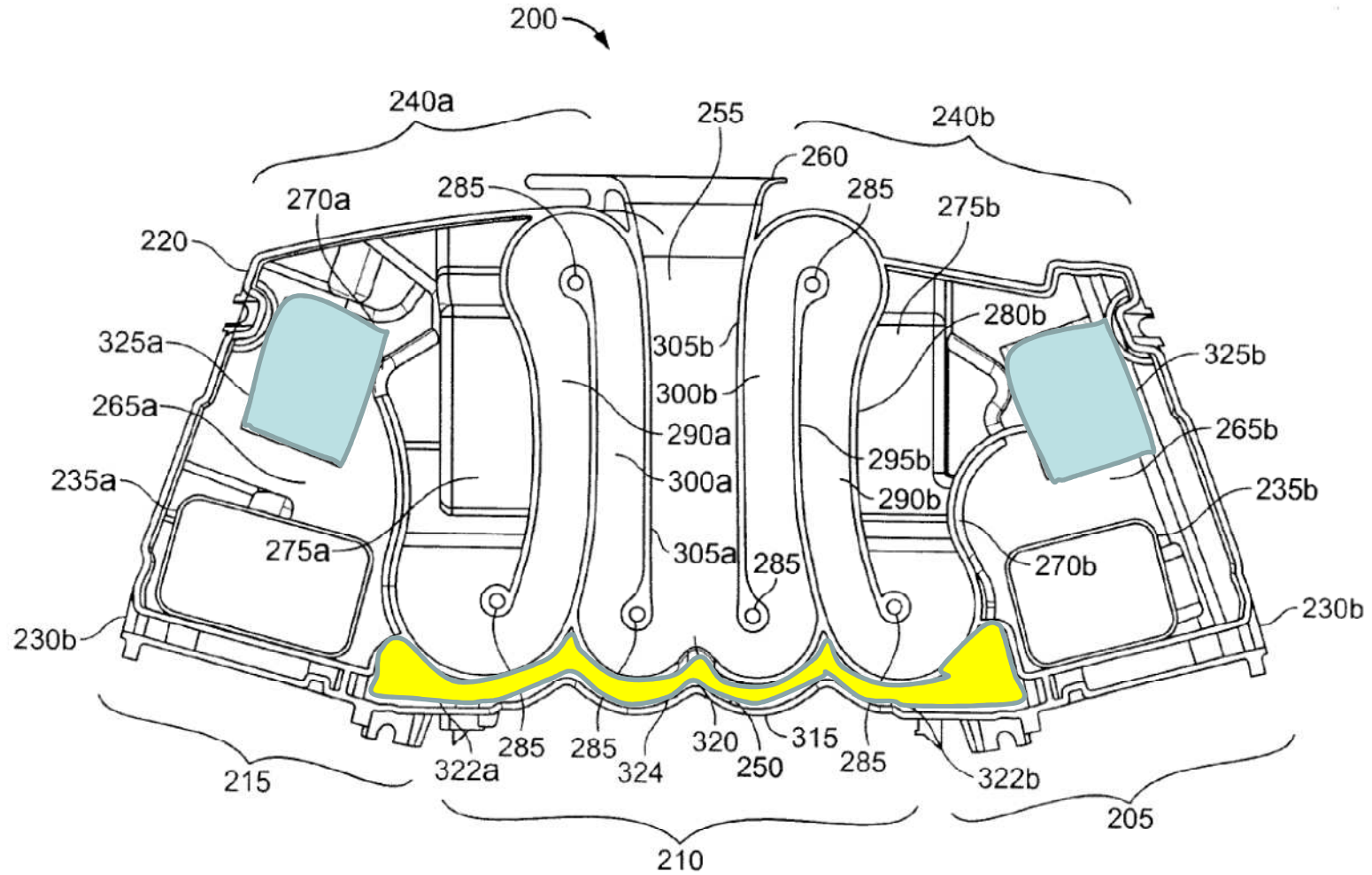

Illustration from: Fig. 6B of U.S. Patent 7,565,948



# Summary

- Viable enclosure types for project
  - sealed box
  - bass reflex / tuned port
  - transmission line / labyrinth
  - coupling chamber + (tapered) damped pipe
- Materials supplied
  - half sheet (4'x4') of 3/4" MDF (cut per your specs)
  - acoustic lining/stuffing material
  - PVC pipe and couplers (per your specs)
  - glue (carpenter's yellow, PVC cleaner/cement)

# References

- *Loudspeaker Design Cookbook, Vance Dickason (any edition)*
- U.S. Patent 3,523,589 “High Compliance Speaker and Enclosure Combination”
- U.S. Patent 4,655,315 “Speaker System”
- U.S. Patent 5,821,471 “Acoustic System”
- U.S. Patent 6,278,789 “Frequency Selective Acoustic Waveguide Damping”
- U.S. Patent 7,426,280 “Electroacoustic Waveguide Transducing”
- U.S. Patent 7,565,948 “Acoustic Waveguiding”
- M. J. King, “Construction and Measurement of a Simple Test Transmission Line,” accessed from <http://www.quarter-wave.com>
- G. L. Augspurger, “Loudspeakers on Damped Pipes,” *J. Audio Eng. Soc.*, vol. 48, pp. 424-436 (2000 May).
- L. J. S. Bradbury, “The Use of Fibrous Materials in Loudspeaker Enclosures,” *J. Audio Eng. Soc.*, vol. 24, pp. 162-170 (1976 April).